

# PARTS LIST

# VW SERIES

## Industrial Sewing Machines

<i>V7001F</i>	<i>W8002D</i>
<i>V7001D</i>	<i>W8003D</i>
<i>V7002D</i>	<i>W8002DE</i>
<i>V7003D</i>	<i>W8003DE</i>
<i>V7002DE</i>	<i>W8002F</i>
<i>V7003DE</i>	<i>W8003F</i>
<i>V7002F</i>	<i>W8002C</i>
<i>V7003F</i>	<i>W8003C</i>
<i>V7002ML</i>	<i>W8004D</i>
<i>L5001M</i>	<i>W8042</i>
<i>L5001MF</i>	<i>W8042-1</i>
<i>L5002TMF</i>	

Industrial Sewing Machines  
**Kansai Special**

## Contents

1. Housing components (カバー機構) .....	1
2. Thread eyelet components (糸道機構) .....	3
3. Thread eyelet components (糸調子機構) .....	5
4. Bushings (ブッシュ機構) .....	6
5. Oil lubrication apparatus (給油機構) .....	7
6. Upper shaft components (上シャフト機構) .....	9
7. Needle lever crank (弓・クランク機構) .....	11
8. Feed rocker (送り台機構) .....	13
9. Loper (ルーパー機構) .....	15
10. Foot lifter components (押え揚げ機構) .....	17
11. Spreader components (上飾り機構) W8000, W8042, W8042-1 W8004D.....	19
<b>Subclass model (サブクラス機構)</b>	
12. Thread eyelet components (糸道機構) W8042, W8042-1 .....	21
13. Feed rocker and looper (送り, 及びルーパー機構) W8042-1 .....	23
14. Feed rocker and looper (送り, 及びルーパー機構) W8042 .....	25
15. Feed rocker and looper (送り, 及びルーパー機構) L5001 .....	27
16. Feed rocker and looper (送り, 及びルーパー機構) L5002 TMF .....	29
17. Organization parts (サブクラス構成部品) L5001M, L5001MF Ruller plate components (定規台関係) .....	31
18. Organization parts (サブクラス構成部品) L5002TMF Looper thread eyelet and ruller plate components (下糸道及び定規台関係).....	33
19. Gauge parts (ゲージ関係) .....	35
20. Attachments (アタッチメント) .....	45
21. Thread stand (糸立て) .....	47
22. Accessories (アクセサリー) .....	49
23. Table stand assembly diagram (テーブルスタンド据付図) .....	50
24. Table diagram (テーブル図) .....	51

# 1. Housing components (カバー機構)

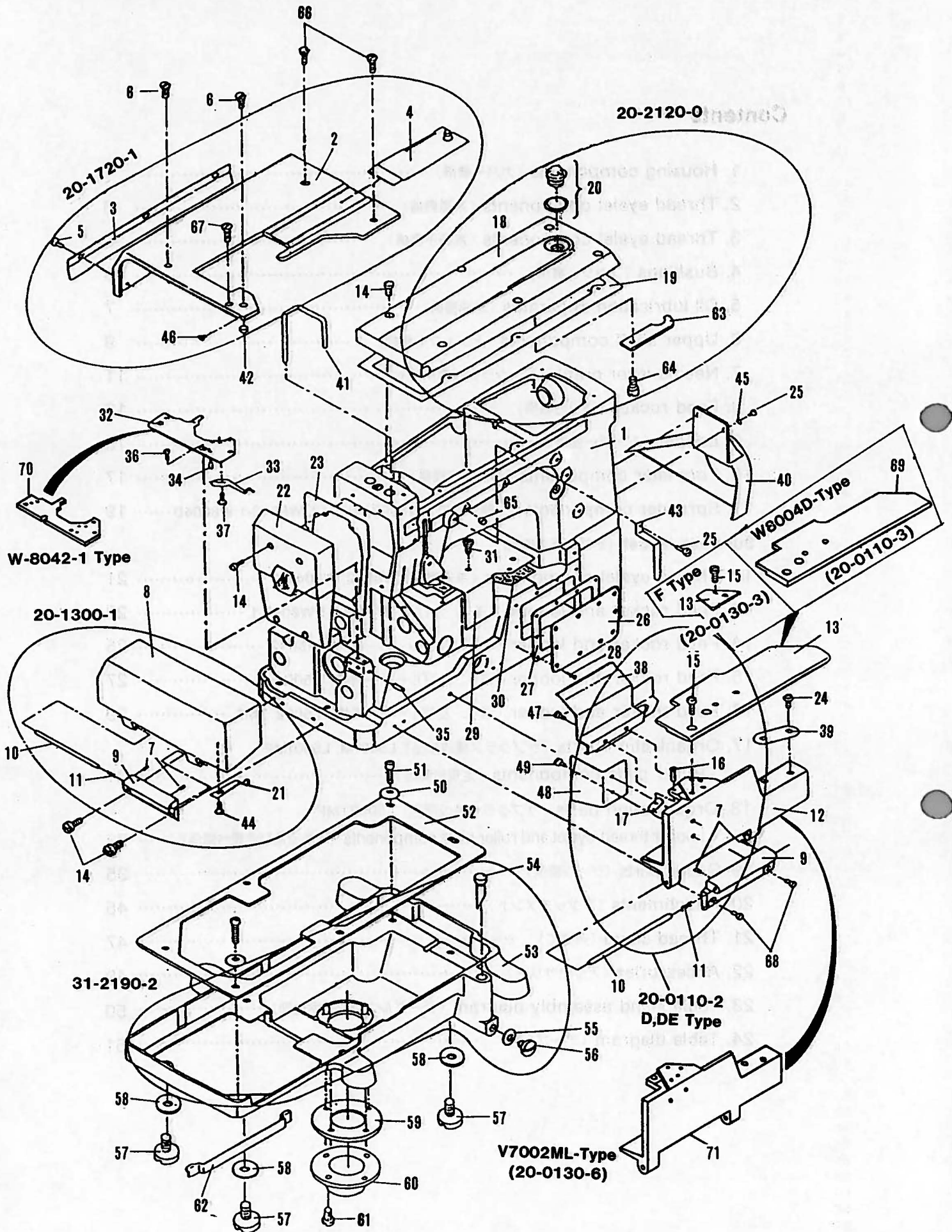

No.	Part No.	Part Name	品名	Standard type	F Type
1	22-8720-0	Arm bed set	アームベッドセット	1	1
	22-8830-0	Arm bed set	アームベッドセット		
2	21-7210-0	Upper cloth plate	上ベースカバー	1	1
3	21-4430-0	Supporting cover	上ベース補助カバー	1	1
4	21-5210-0	Slide plate	差板	1	1
5	84-5740-0	Screw	ネジ	3	3
6	84-8620-0	Screw	ネジ	2	2
7	84-3140-0	Screw	ネジ	4	4
8	21-3520-0	Slide cover	横ベースカバー C	1	1
9	25-1080-0	Hinge	定規台取付ヒンジ	2	2
10	71-3080-0	Hinge pin	ヒンジピン	2	2
11	79-2330-0	Spring	取付巻バネ	2	2
12	21-1830-0	Ruller holder A	定規台	1	1
13	21-1920-0	Ruller plate A	定規板	1	
	21-1910-0	Ruller plate	定規板		1
14	84-5660-0	Screw	ネジ	10	10
15	84-5720-0	Screw	ネジ	2	2
16	84-4620-0	Screw	ネジ	2	2
17	71-4010-0	Setting pin for ruller holder spring	定規台裏バネピン	1	1
18	21-2120-0	Crank chamber oil cover	立ロットカバー	1	1
19	23-8030-0	Crank chamber oil cover packing	立ロットカバーパッキン	1	1
20	39-2330-0	Oil pot lid	オイルポット	1	1
21	79-5020-0	Spring	横ベースカバー板バネ	1	1
22	20-8050-0	Head cover	面板	1	1
23	23-2390-0	Head cover gasket	面板パッキン	1	1
24	85-1810-0	Screw	ネジ	2	2
25	84-5710-0	Screw	ネジ	5	5
26	21-1220-0	Oil reservoir front cover	前油カバー	1	1
27	23-2340-0	Oil reservoir front cover gasket	前油カバーパッキン	1	1
28	84-6640-0	Screw	ネジ	8	8
29	21-4980-0	Oil reservoir top cover	上油カバー	1	1
30	23-2290-0	Oil reservoir top cover gasket	上油カバーパッキン	1	1
31	84-6610-0	Screw	ネジ	5	5
32	14-0310-2	Needle plate support	針板土台	1	1
33	79-5010-0	Ruller holder spring	定規板板バネ	1	1
34	71-2510-0	Knock pin	針板ノックピン	2	2
35	71-3010-0	Pin	横ベースカバー板バネピン	1	1
36	84-7610-0	Screw	ネジ	2	2
37	84-3610-0	Screw	ネジ	2	2
38	21-1000-0	Oil cover	オイルフェンス	1	1
39	26-7120-0	Folider base bracket	ラッパ取付台	1	1
40	21-4020-0	Pulley cover	プーリーカバー	1	1
41	21-7030-0	Needle ber eyelet safety ber	針棒糸道保護バー C	1	1
42	71-1190-0	Ruller plate stopper	定規台ストッパー	1	1
43	21-7120-0	Needle lever eyelet safety plate	弓糸道保護バー	1	1
44	84-5710-0	Screw	ネジ	1	1
45	75-4550-0	Washer	ワッシャ	2	2
46	25-8010-0	Cushion	2枚カバー防振ゴム	3	3
47	84-5640-0	Screw	ネジ	2	2
48	21-1850-0	Slide cover	定規台サイドカバー	1	1
49	84-3640-0	Screw	ネジ	2	2
50	75-4520-0	Washer	ワッシャ	2	2
51	85-6280-0	Screw	ネジ	2	2
52	23-1590-0	Packing	オイルタンクパッキン	1	1
53	31-2190-2	Oil tank set	オイルタンクセット	1	1
54	39-2160-0	Oil gauge E	オイルゲージ E	1	1
55	23-3040-0	Drain seal	オイルタンクドレンシール	1	1
56	87-3110-0	Screw	ネジ	1	1
57	85-2200-0	Screw	ネジ	4	4
58	23-1200-0	Oil tank packing	オイルタンクパッキン	4	4
59	23-9130-0	Oil filter packing	オイルフィルター受パッキン	1	1
60	35-9150-0	Oil filter plate	オイルフィルター受	1	1
61	84-7630-0	Screw	ネジ	4	4
62	39-1670-0	Oil fence	オイルタンク用フェンス	1	1
63	39-1370-0	Tubu support B	配管B用サポート	1	1
64	84-1610-0	Screw	ネジ	1	1
65	23-1750-0	Gom	ゴム	1	1
66	84-8610-0	Screw	ネジ	2	2
67	84-6640-0	Screw	ネジ	1	1
68	84-5710-0	Screw	ネジ	2	2
69	21-1940-0	Ruller plate	定規板 W8004D タイプ		
70	14-0320-2	Needle plate support	針板土台 W8042-1タイプ		
71	21-1890-0	Ruller holder	定規台 V7002 MLタイプ		

## 2. Thread eyelet components (糸道機構)

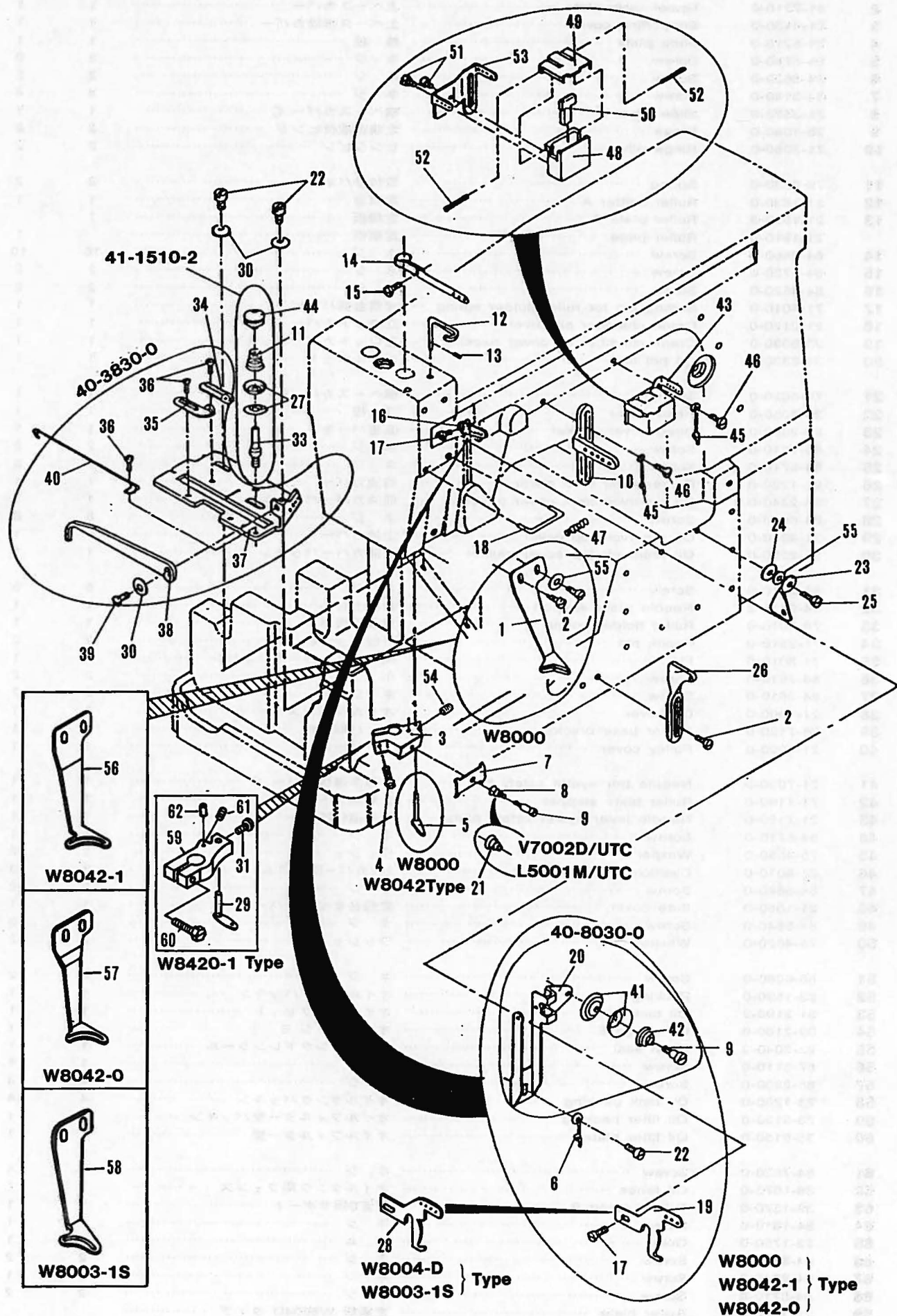

No.	Part No.	Part Name	品 名	L5001 V7000	W8000
1	45-9230-0	Zigzag thread eyelet	糸道 D		1
2	84-3610-0	Screw	ネ ジ	2	4
3	41-3040-1	Nipper bracket	針株クランプ糸道台	1	1
4	84-4130-0	Screw	ネ ジ	1	1
5	45-9140-0	"L"Thread eyelet	L型糸道		1
6	47-1490-0	Upper thread guide eyelet	上飾糸案内糸道		1
7	45-1420-0	Tension nipper	カメ糸道 B	1	1
8	41-7210-0	Tension nipper spring	カメ糸道押しバネ	1	1
9	84-1710-0	Screw	ネ ジ	1	2
10	45-0810-0	Needle thread eyelet	上糸糸道W3	1	1
11	41-1530-0	Spring	バネ	1	1
12	45-2510-0	Needle thread take-up wire	上糸受け	1	1
13	84-5210-0	Screw	ネ ジ	1	1
14	45-1810-0	Needle bar thread eyelet	針株糸道	1	1
15	84-3610-0	Screw	ネ ジ	1	1
16	45-0910-0	Needle thread retainer eyelet	上糸捌き糸道	1	
17	84-5740-0	Screw	ネ ジ	1	1
18	45-2460-0	Guide pin	上糸ガイドピン	1	1
19	45-0960-0	Needle lever thread eyelet	上糸テンビン捌き糸道		1
20	45-0940-0	Covering looper thread eyelet	上糸捌き調節糸道		1
21	41-7220-0	Tension nipper spring	カメ糸道押しバネ	1	
22	84-5740-0	Screw	ネ ジ	1	1
23	41-4160-0	Looper thread eyelet	12本針糸立て糸道		1
24	23-1870-0	O-ring	Oリング	1	1
25	84-3740-0	Screw	ネ ジ	1	1
26	45-1000-0	Looper thread eyelet	上糸糸道 (上)	1	1
27	41-1550-0	Tension nipper	捌き用小チャンポン皿	2	2
28	45-0950-0	Needle lever thread eyelet	上糸テンビン捌き糸道		1
29	45-9160-0	"L"Thread eyelet	L型糸道 W8420-1		1
30	75-4680-0	Washer	ワッシャ	3	3
31	84-1610-0	Screw	ネジ W8420-1		1
32	47-2030-0	Looper thread eyelet guide	下糸案内糸道 C	1	1
33	41-1510-0	Looper thread guide tension stud	上糸チャンポン用調子棒	1	1
34	47-1320-0	Looper thread eyelet (left)	下糸捌き板案内糸道 (左)	1	1
35	47-1310-0	Looper thread guide eyelet (right)	下糸捌き板案内糸道 (右)	1	1
36	84-1610-0	Screw	ネ ジ	3	3
37	43-3420-0	Cast off support bracket	下糸捌き板	1	1
38	43-3440-0	Looper thread retainer	下糸捌き上	1	1
39	84-3610-0	Screw	ネ ジ	1	1
40	43-3380-0	Looper thread retainer	下糸捌き下ピン	1	1
41	41-1560-0	Tension nipper	上飾り捌き小チャンポン皿		2
42	41-1570-0	Tension nipper spring	上飾り捌き調子バネ		1
43	20-5320-0	Silicon tank set	シリコンタンクセット	1	1
44	41-1540-0	Nut	ナット	1	1
45	47-1440-0	Thread eyelet	糸道		2
46	84-5710-0	Screw	ネ ジ	2	2
47	79-2280-0	Spring	上糸ガイドバー用バネ	1	1
48	27-5310-0	Silicon tank	シリコンタンク	1	1
49	27-5330-0	Silicon tank lid	シリコンタンク フタ	1	1
50	27-5340-0	Felt	フェルト	1	1
51	84-1610-0	Screw	ネ ジ	2	2
52	71-2020-0	Pin	ピン	2	2
53	45-1690-0	Thread eyelet	糸道	1	1
54	84-1120-0	Screw	ネ ジ		1
55	75-4550-0	Washer	ワッシャ	1	2
56	45-8400-0	Zigzag thread eyelet	への字糸道 W8042-1		1
57	45-9240-0	Zigzag thread eyelet	への字糸道 W8042-0		1
58	45-9260-0	Zigzag thread eyelet	への字糸道 W8003-IS		1
59	45-8410-0	Nipper bracket	針株クランプ W8420-1		
60	84-4130-0	Screw	ネジ W8420-1		1
61	84-1120-0	Screw	ネジ W8420-1		1
62	71-1660-0	Pin	ピン W8420-1		1

### 3. Thread eyelet components (糸調子機構)

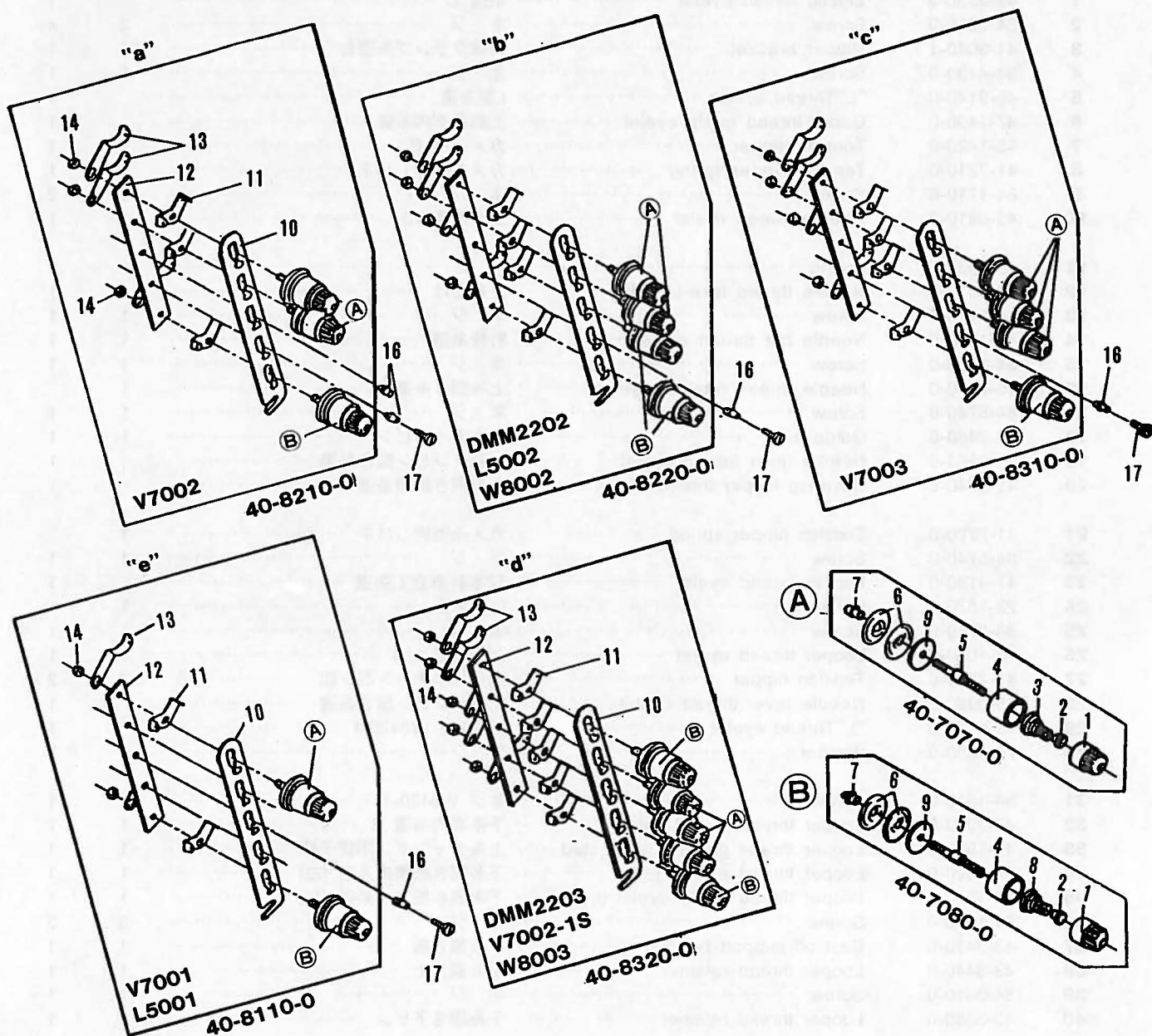

No.	Part No.	Part Name	品名	"d"	"b"	"c"	"a"	"e"
1	41-1010-0	Adjusting nut	チャンポン皿小ケース	5	4	4	3	2
2	41-1050-0	Adjusting ratchet	チャンポン皿ラチェット	5	4	4	3	2
3	41-7010-0	Spring strong	チャンポン調子バネ強	3	2	3	2	1
4	41-1070-0	Disc cover	チャンポン皿大ケース	5	4	4	3	2
5	41-1720-0	Tension post	調子棒中	5	4	4	3	2
6	41-1110-0	Disc	チャンポン皿	10	8	8	6	4
7	41-1310-0	Collar	調子棒カラーA	5	4	4	3	2
8	41-7020-0	Spring weak	チャンポン調子バネ弱	2	2	1	1	1
9	23-3240-0	Felt	取付けフェルト	5	4	4	3	2
10	41-236B-0	Tension post support	チャンポン皿調節板	1	1	1	1	1
11	41-1150-0	Thread eyelet	糸道上	5	4	4	3	2
12	41-237B-0	Tension post holder	チャンポン元板	1	1	1	1	1
13	41-1170-0	Thread eyelet	糸道下	5	4	4	3	2
14	86-4110-0	Nut	ナット	5	4	4	3	2
16	41-1320-0	Collar B	カラーB		1	1	2	2
17	84-7640-0	Screw	ネジ		1	1	2	2

## 4. Bushings (ブッシュ機構)

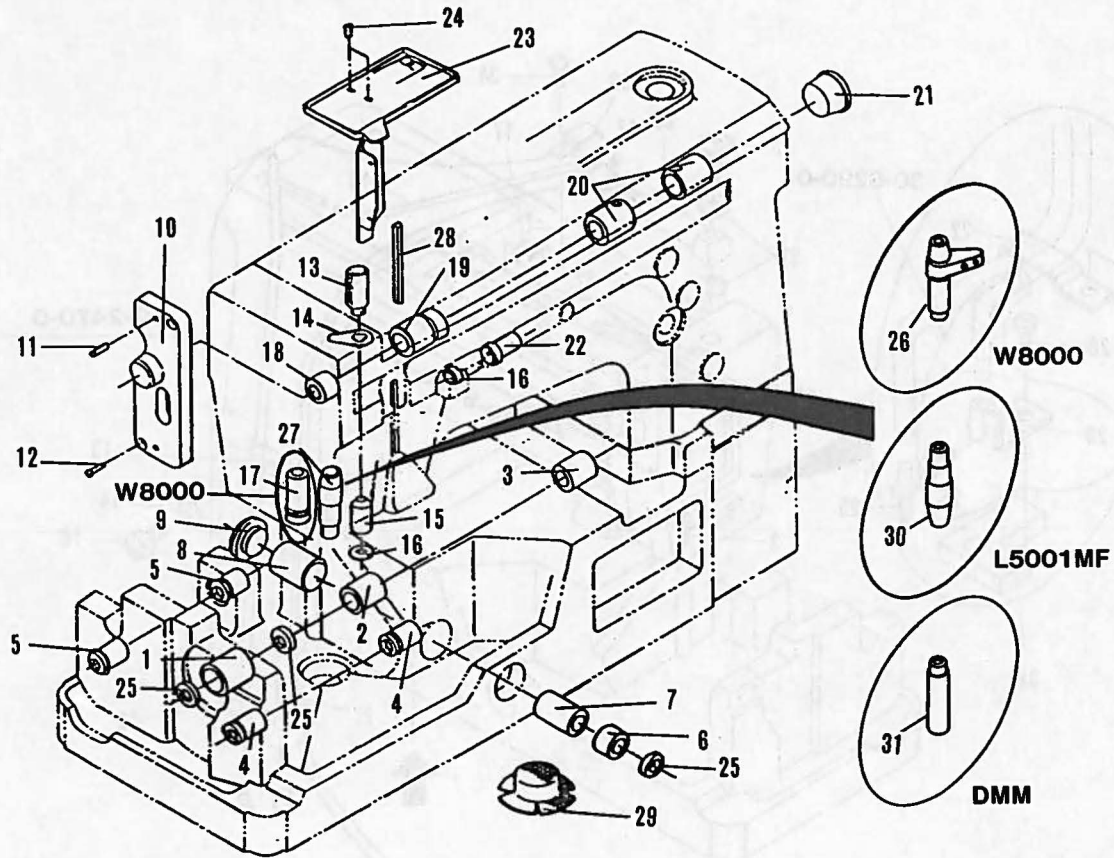

No.	Part No.	Part Name	品名	L5000			
				DMM	V7000	W8000	L5001MF
1	81-7140-0	Bushing	下シャフトブッシュ (前)	1	1	1	1
2	81-7200-0	Bushing	下シャフトブッシュ	1	1	1	1
3	81-8070-0	Bushing	下シャフトブッシュ (後)	1	1	1	1
4	81-7350-0	Bushing	ルーバーシャフトブッシュ左B	2	2	2	2
5	81-7530-0	Bushing	送り台シャフトブッシュ	2	2	2	2
6	81-2390-0	Bushing	ルーバー振元シャフトブッシュ	1	1	1	1
7	81-2360-0	Bushing	ルーバー振元シャフトブッシュ	1	1	1	1
8	81-2370-0	Bushing	振元シャフトブッシュC	1	1	1	1
9	23-2960-0	Seal cap	上シャフトシールキャップ	1	1	1	1
10	69-8030-0	Bushing support	ブッシュサポート	1	1	1	1
11	71-2160-0	Pin	ルーバーアジャストピン	2	2	2	2
12	84-7630-0	Screw	ネジ	2	2	2	2
13	81-2060-0	Bushing	針棒ブッシュ	1	1	1	1
14	39-8010-0	Oil fence	針棒オイルフェンス	1	1	1	1
15	81-2090-0	Bushing	針棒ブッシュ	1	1	1	1
16	94-2310-0	Oil seal	シャフトシール	2	2	2	2
17	81-1490-0	Bushing W8000Type	上飾り土台ブッシュ			1	
18	81-8030-0	Bushing	上シャフトベッドブッシュ	1	1	1	1
19	81-0810-0	Bushing	上シャフトブッシュ	1	1	1	1
20	81-0820-0	Bushing	上シャフトブッシュ	2	2	2	2
21	23-8000-0	O-ring	Oリング	1	1	1	1
22	81-8080-0	Bushing	アームクランクブッシュ	1	1	1	1
23	39-8030-0	Oil fence	天秤オイルフェンス	1	1	1	1
24	84-4620-0	Screw	ネジ	2	2	2	2
25	94-2140-0	Oil seal	オイルシール	3	3	3	3
26	81-1620-0	Bushing W8000Type	押工棒ブッシュ			1	
27	81-1630-0	Bushing V7000Type	押工棒ブッシュ		1		
28	39-8060-0	Rubber	オイルフェンスゴム	1	1	1	1
29	31-4380-0	filter	ベツトフィルター	1	1	1	1
30	81-2630-0	Bushing L5001MF-Type	押え棒ブッシュL5001MF				1
31	81-2220-0	Bushing DMM-Type	押え棒ブッシュDMM	1			



# 5. Oil lubrication apparatus (給油機構)

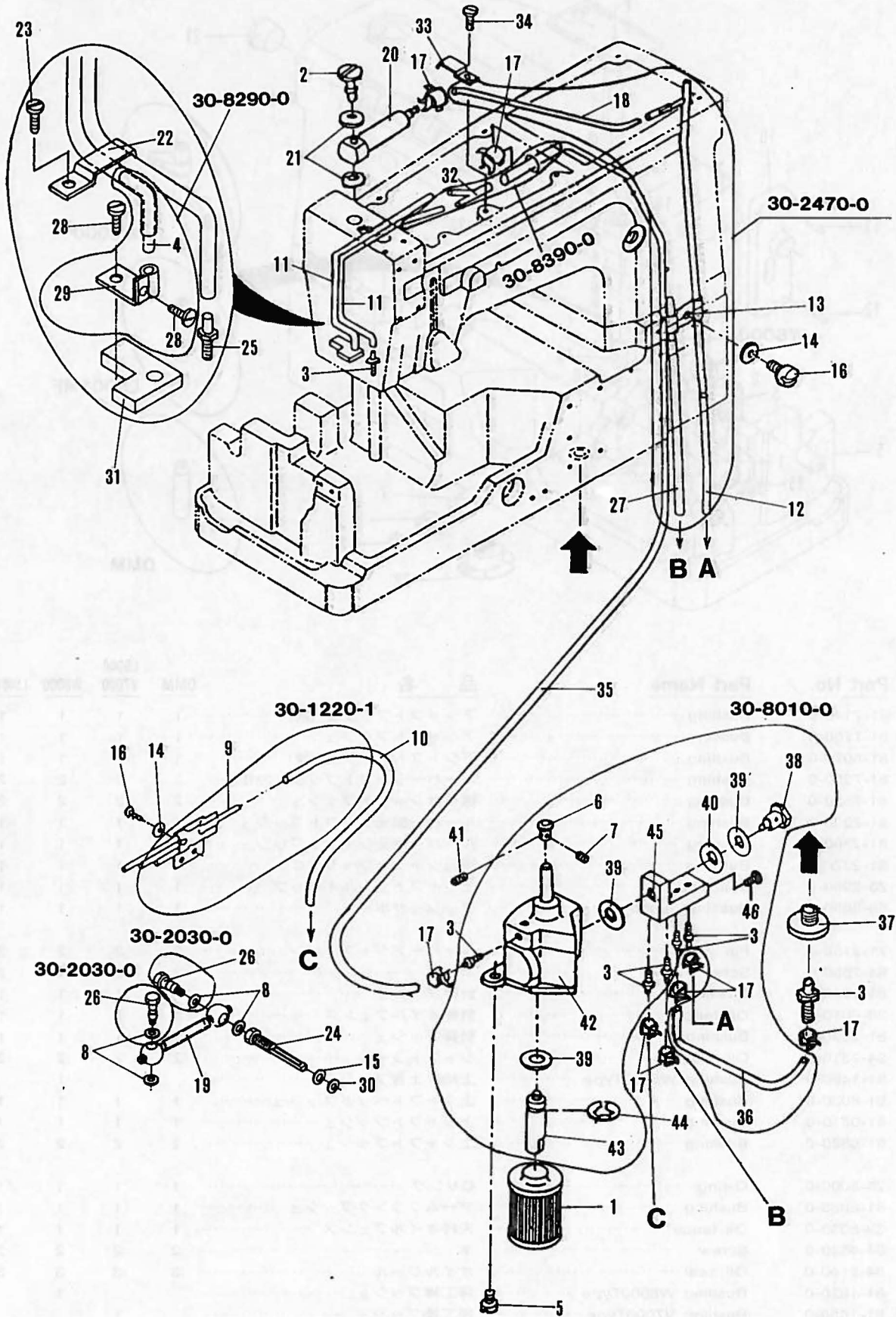

No.	Part No.	Pa. Name	品 名	Q, ty
1	31-2220-0	Oil filter	オイルフィルター	1
2	35-8320-0	Oil splash screw	上シャフト配管ジョイントネジ	2
3	31-3140-0	Pipe joint	ビニールパイプ継手C	6
4	35-8290-0	Pipe	面板オイルバックパイプ	1
5	84-5660-0	Screw	ネジ	2
6	31-4090-0	Gear	ポンプウォーム歯車	1
7	84-5210-0	Screw	ネジ	1
8	23-9110-0	Oil tube washer	ワッシャ	4
9	35-1220-0	Pipe	セパレート配管	1
10	35-3150-0	Vinyl pipe (190 ℓ)	ビニールパイプ大 190 ℓ	1
11	35-3240-0	Vinyl pipe (250 ℓ)	ビニールパイプ小 B (250 ℓ)	2
12	35-3170-0	Vinyl pipe (290 ℓ)	ビニールパイプ大 (290 ℓ)	2
13	35-2470-0	Piping	立てロット用配管 B	1
14	23-1600-0	Seal	配管油止シール	3
15	75-4700-0	Drain seal	オイルタンクドレンシール	1
16	84-3670-0	Screw	ネジ	3
17	35-4120-0	Pipe support	配管チューブ止金具	5
18	35-3140-0	Vinyl pipe 125 ℓ	ビニールパイプ大 125 ℓ	1
19	30-5000-0	Felt	Rフェルト	1
20	35-8310-0	Vinyl tube coupling	上シャフト配管ジョイント	1
21	23-3060-0	Packing	配管油止シール	4
22	39-1380-0	Pipe support E	パイプサポートE	1
23	84-3610-0	Screw	ネジ	3
24	35-2040-1	Oil flow screw	オイルフォローネジ	1
25	31-3640-0	Pipe	ビニールパイプ継手E	1
26	35-2030-0	Oil guide screw	送り台オイル案内ネジB	2
27	35-3410-0	Vinyl tube (240 ℓ)	ビニールチューブ (240 ℓ)	1
28	84-3610-0	Screw	糸道カバー止メネジ	2
29	35-1610-0	Pipe bracket	パイプ取付金具	1
30	23-1640-0	Pomp tube joint seal	ポンプチューブジョイントシール	1
31	23-3430-0	Oil back felt	オイルバックフェルト	1
32	35-8390-0	Oil back joint	オイルバックジョイント	1
33	39-1390-0	Pipe support	パイプサポート	1
34	84-5740-0	Screw	カバー止メネジ	1
35	35-3180-0	Vinyl tube (440 ℓ)	ビニールチューブ (440 ℓ)	1
36	35-3430-0	Vinyl tube (80 ℓ)	ビニールチューブ (80 ℓ)	1
37	85-5310-0	Screw	上糸糸道取付ネジ	1
38	35-8220-0	Screw	ポンプ配管ネジ	1
39	75-4700-0	Washer	ドレンワッシャB	3
40	23-1640-0	Pomp tube joint seal	ポンプチューブジョイントシール	1
41	84-5110-0	Screw	針止メネジ	1
42	30-0150-0	Pomp set	ポンプセット	1
43	35-1070-0	Filter tube	フィルター用吸口	1
44	93-2230-0	Ering	Eリング	1
45	31-2490-0	Oil separator	オイルセパレータ	1
46	84-6610-0	Screw	ネジ	1

# 6. Upper shaft components (上シャフト機構)

W8042-1  
W8042

L5002TMF  
W8003-1S  
V7002-1S

DMM2200

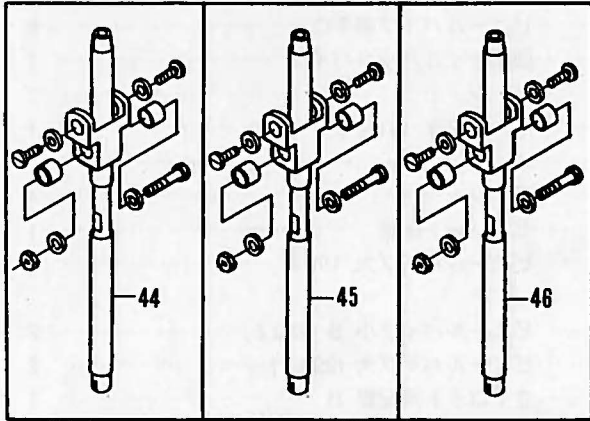

60-8010-1

60-8020-1

60-8020-1

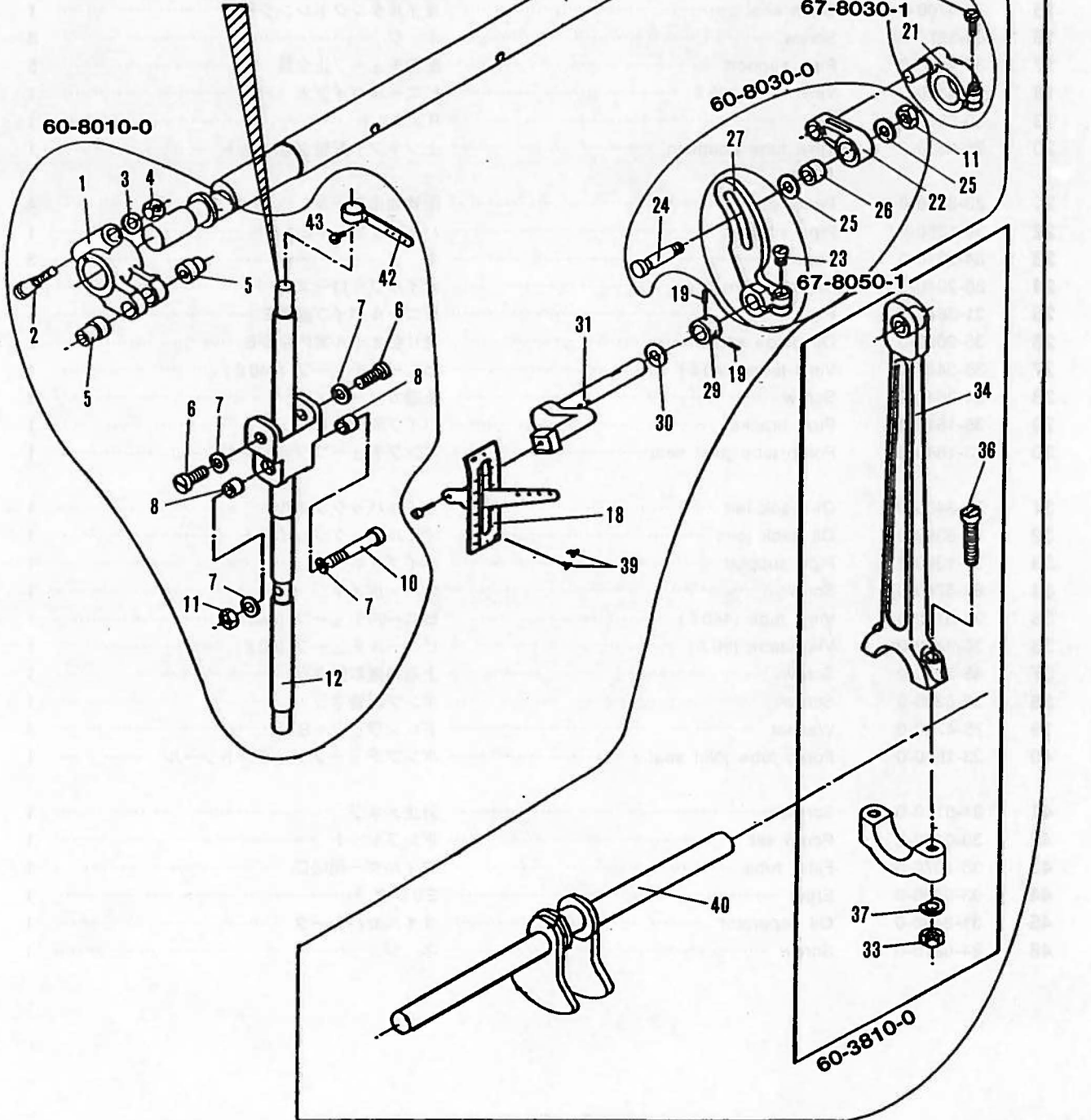

No.	Part No.	Part Name	品 名	Q, ty
1	67-8010-0	Needle bar crank lever	針棒クランクレバー	1
2	71-4550-0	Thread pin	立ロット連結レバー止ピン	2
3	75-3810-0	Washer	ワッシャ	2
4	86-5010-0	Nut	ナット	2
5	71-5010-0	Upper pin	針棒連結リンクピン	2
6	84-4010-0	Screw	ネジ	2
7	75-5220-0	Washer	ワッシャ	4
8	75-2490-0	Lever bush	針棒リンクローラー	2
9	66-8020-0	Needle bar joint	針棒連結リンク	1
10	84-6170-0	Screw	ネジ	1
11	86-3110-0	Nut	ナット	2
12	11-8010-0	Needle bar	針棒	1
13	71-6930-0	Upper shaft C	上シャフトC	1
14	67-8020-0	Crank lever	立ロット連結レバー	1
15	75-3060-0	Washer	ワッシャ	2
16	75-1060-0	Collar	カラー	2
17	85-2130-0	Screw	ネジ	1
18	24-1030-0	Plate	目盛板B	1
19	84-5110-0	Screw	ネジ	2
20	71-5060-0	Pin	ピン	1
21	67-8030-1	Thread tension lever	上糸捌き駆動レバー	1
22	66-8010-0	Thread tension regulating link	上糸調節連結リンク	1
23	84-8140-0	Screw	ネジ	2
24	84-5990-0	Screw	ネジ	1
25	75-5220-0	Washer	ワッシャ	2
26	75-2480-0	Roller	ローラー	1
27	67-8050-0	Thread tension regulating lever	上糸調節レバー	1
28	85-1130-0	Screw	ネジ	2
29	75-1520-1	Collar	カラー	1
30	75-3560-0	Washer	ワッシャ	1
31	69-8010-0	Arm crank	アームクランク	1
32	75-5520-0	Washer	ワッシャ	1
33	86-3150-0	Nut	ナット	2
34	60-3810-0	Crank rod	針棒クランクロッド	1
35	84-5210-0	Screw	ネジ	2
36	84-6210-0	Screw	ネジ	2
37	75-3880-0	Washer	ワッシャ	2
38	84-5740-0	Screw	ネジ	1
39	93-7010-0	Pin	ピン	2
40	71-8870-0	Clank shaft	クランクシャフト	1
42	45-1810-0	Needle bar thread eyelet	針棒糸道	1
43	84-3610-0	Screw	ネジ	1
44	11-8420-0	Needle bar (W8042-1,W8042)	針棒 (W8042-1,W8042)	1
45	11-7020-0	Needle bar (W8003-1S,V7002-1S)	針棒 (W8003-1S,V7002-1S)	1
46	11-8020-0	Needle bar (DMM2200)	針棒DMM2200	1

# 7. Needle lever crank (弓・クランク機構)

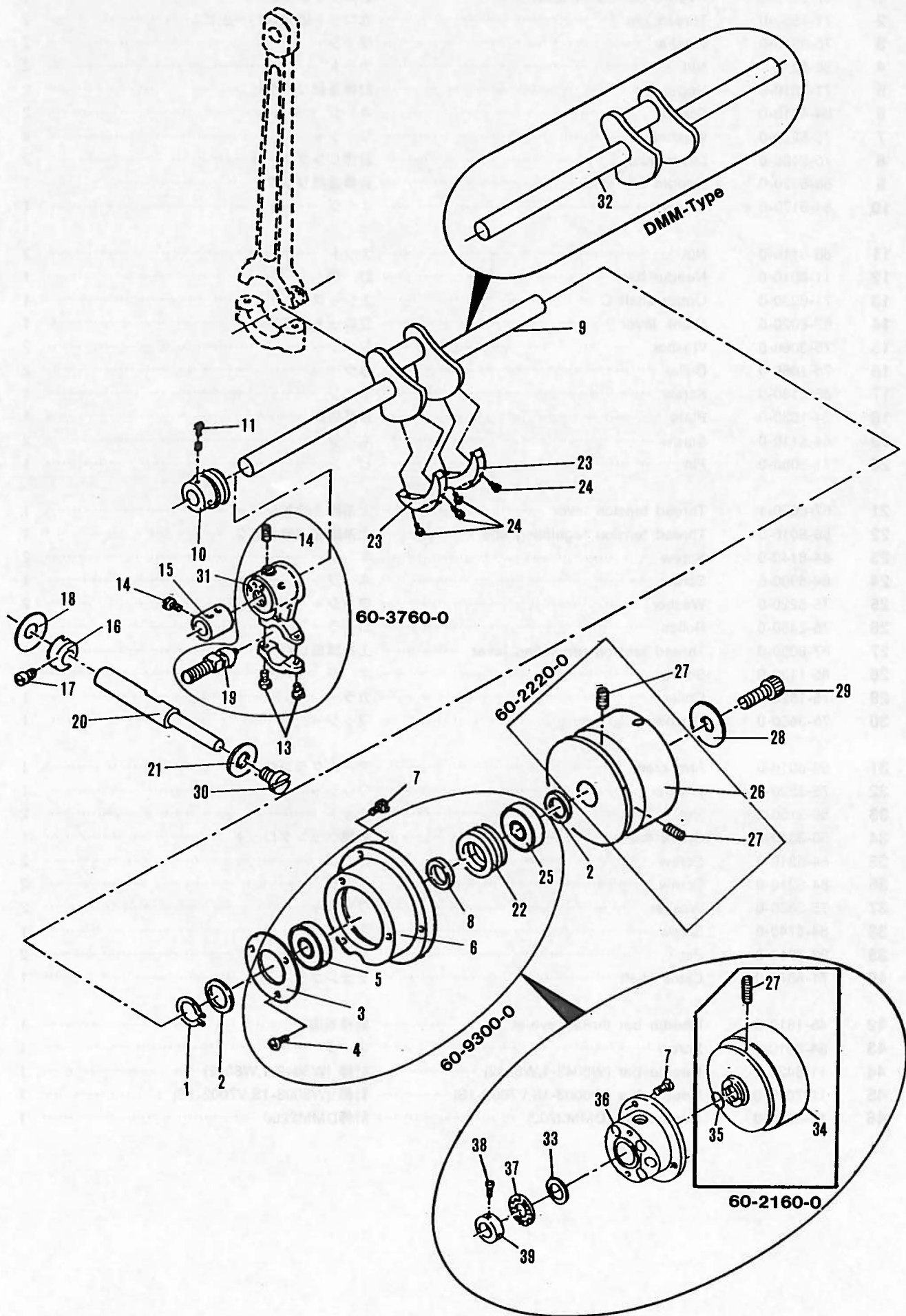

No.	Part No.	Full Name	品 名	V.W	DMM
1	94-8100-0	C-ring	スナップリング	1	
2	75-8140-0	Washer	ベアリングスラストワッシャ	2	
3	69-1530-0	Set plate for bearing	ベアリング止板	1	
4	84-5630-0	Screw	ネジ	3	
5	91-9020-0	Bearing	ベアリング	1	
6	69-3110-0	Flange	フランジ	1	
7	84-5660-0	Screw	ネジ	3	3
8	75-1600-0	Collar	ベアリングスペースカラー	1	
9	71-8870-0	Crank shaft	クランクシャフト	1	
10	31-4100-0	Worm gear	ポンプウォームホイール	1	1
11	84-7180-0	Screw	ネジ	2	2
12	67-3760-U	Looper driving lever ball joint	ルーバー振元ロッド	1	1
13	84-5720-0	Screw	ネジ	2	2
14	85-1130-0	Screw	ネジ	8	8
15	75-1010-0	Collar	クランクジョイントカラー	1	1
16	75-1070-1	Collar	ルーバー振元カラー	1	1
17	85-2120-0	Screw	ネジ	1	1
18	75-3220-0	Washer	ルーバー振元軸スラストワッシャ	1	1
19	61-7130-U	Looper driving eccentric	ルーバー振元ロット玉	1	1
20	71-6130-0	Looper driving shaft B	ルーバー振元シャフトB	1	1
21	75-3320-0	Washer	メインシャフトワッシャ	1	1
22	79-0600-0	Spring	フランジ皿バネ	4	
23	69-1470-0	Balance	クランクシャフトバランスウェイト	2	2
24	84-5710-0	Screw	ネジ	4	4
25	91-9030-0	Bearing	ベアリング	1	
26	69-222G-0	Pulley	プーリー	1	
27	85-1140-0	Screw	ネジ	2	2
28	75-1830-0	Washer	プーリースラストワッシャ	1	
29	87-2630-0	Bolt M8	M8ボルト	1	
30	84-5740-0	Screw	ネジ	1	1
31	61-5140-0	Eccentric	エキセントリック	1	1
32	71-8810-0	Crank shaft	クランクシャフト		1
33	75-3270-0	Washer	ワッシャ		1
34	69-2160-0	Pulley	プーリーJ		1
35	23-1970-0	O-ring	12.50リング		1
36	69-3050-2	Flange	フレンジE		1
37	92-2310-0	Bearing	13.45スラストベアリング		1
38	84-5630-0	Screw	ネジ		2
39	75-1120-1	Crank shaft collar	クランクシャフトカラー小		1

# 8. Feed rocker (送り台機構)

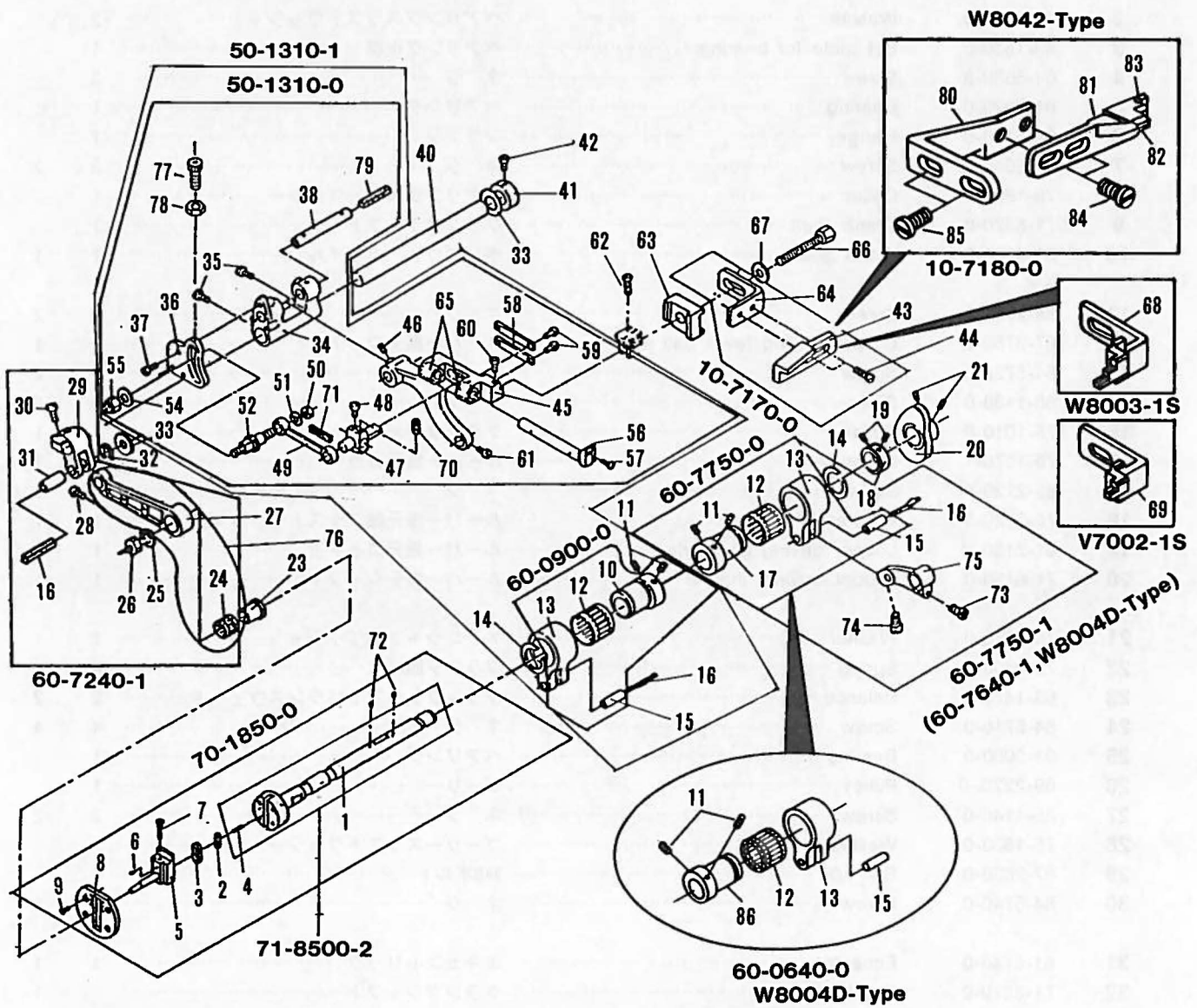

No.	Part No.	Part Name	品名	Q,ty
1	71-7850-0	Main shaft 8E	前下シャフト8E	1
2	51-0360-0	Oil guard	送り調節芯棒オイルガード	1
3	23-1970-0	O-ring	O-リング	1
4	23-3930-0	Felt	フェルト	1
5	51-0130-0	Feed crank adjusting post C	送り調節芯棒 (C)	1
6	85-6240-0	Screw	ネジ	1
7	84-3830-0	Screw	ネジ	1
8	51-0310-0	Main shaft plate	メインシャフトプレート	1
9	84-6610-0	Screw	ネジ	4
10	61-3220-0	Feed eccentric	送りエキセン玉	1
11	84-5210-0	Screw	ネジ	4
12	91-4060-0	Bearing	エキセンダルマ	2
13	63-2320-U	Eccentric link	エキセンダルマ	2
14	93-4060-0	Snap ring	サークリップ	2
15	71-4310-0	Connecting link pin	ダルマピン	2
16	23-3410-0	Felt	フェルト	3
17	61-3140-0	Looper avoid eccentric	針返しエキセン玉 (0.75)	1
18	75-1140-1	Collar	カラー	1
19	84-5110-0	Screw	ネジ	2
20	49-1390-1	Looper thread double disk	ハマグリ	1

No.	Part No.	Part Name	品名	Q, ty
21	84-7110-0	Screw	ネジ	2
23	75-2450-0	Feed crank link collar	カラー	1
24	91-2670-0	Bearing	ベアリング	1
25	75-1640-0	Washer	ワッシャ	1
26	86-4120-0	Nut	ナット	1
27	67-3140-0	Feed rocker arm	送り連結レバー	1
28	84-3660-0	Screw	ネジ	2
29	63-3570-0	Feed rocker link	送りダルマC	1
30	84-8140-0	Screw	ネジ	1
31	71-4130-0	Feed rocker link pin	ダルマピン	1
32	93-2610-0	Snap link	止輪	1
33	75-3720-0	Washer	ワッシャ	2
34	51-1020-0	Differential feed rocker	2枚送り元台B	1
35	84-5210-0	Screw	ネジ	2
36	51-1050-0	Feed rocker segment shot plate	2枚送り調節板	1
37	84-3630-0	Screw	ネジ	3
38	71-5310-0	Shaft	後送歯取付シャフト	1
39	84-5760-0	Screw	ネジ	1
40	71-6470-0	Feed rocker arm shaft	2枚送元台シャフト	1
41	75-1320-1	Collar	カラー	1
42	84-8160-0	Screw	ネジ	1
43	18-7190-0	Needle guard G	針受けG	1
44	84-1610-0	Screw	ネジ	2
45	51-1030-0	Main differential feed	2枚送土台A	1
46	84-5210-0	Screw	ネジ	1
47	51-1090-0	Differential feed bar guide	前送り台抱き	1
48	84-3790-0	Screw	ネジ	1
49	66-5060-0	Feed crank link	連結クランク	1
50	86-3110-0	Nut	ナット	1
51	75-4670-0	Washer	ワッシャ	1
52	51-1130-0	Crank set pin	クランク取付ピン	1
54	75-4580-0	Washer	ワッシャ	1
55	86-4110-0	Nut	ナット	1
56	51-1200-0	Front feed dog holder bracket	前送歯取付台B	1
57	84-3630-0	Screw	ネジ	1
58	51-1110-0	Differential feed bar guide	前送台抱きガイド	2
59	84-1640-0	Screw	ネジ	4
60	84-4640-0	Screw	ネジ	1
61	84-3660-0	Screw	ネジ	1
62	84-1620-0	Screw	ネジ	2
63	18-7090-0	Needle guard holder	針受け取付金具B	1
64	18-7200-0	Needle guard holder B	針受け取付板B	1
65	81-1410-0	Bushing	ブッシュ	2
66	84-6140-0	Screw	ネジ	1
67	75-4550-0	Washer	ワッシャ	1
68	18-7830-0	Needle guard W8003-IS	針受け W8003-IS	1
69	18-7920-0	Needle guard V7002-IS	針受け V7002-IS	1
70	84-3140-0	Screw	ネジ	1
71	23-3910-0	Felt	フェルト	1
72	23-3410-0	Felt	フェルト	1
73	84-6120-0	Screw	ネジ	1
74	84-7610-0	Screw	ネジ	1
75	67-1320-1	Looper avoid lever	針返しダルマレバー	1
76	60-7240-0	Feed rocker arm set	送り連結レバーベアリングセット	1
77	87-1360-0	Screw	ネジ	1
78	88-1360-0	Nut	ナット	1
79	23-3910-0	Felt	フェルト	1
80	18-8410-0	Needle guard mount W8042	針受け取付金具 W8042	1
81	18-8420-0	Needle guard (rear) W8042	針受け後 W8042	1
82	18-8430-0	Needle guard (front) W8042	針受け前 W8042	1
83	84-1120-0	Screw	ネジ	1
84	84-5740-0	Screw	ネジ	2
85	84-5710-0	Screw	ネジ	2
86	61-9040-0	Looper avoid eccentric 0.65 (W8004DType)	針返しエキセン玉 (W8004DType)	1



# 9. Looper (ルーパー機構)

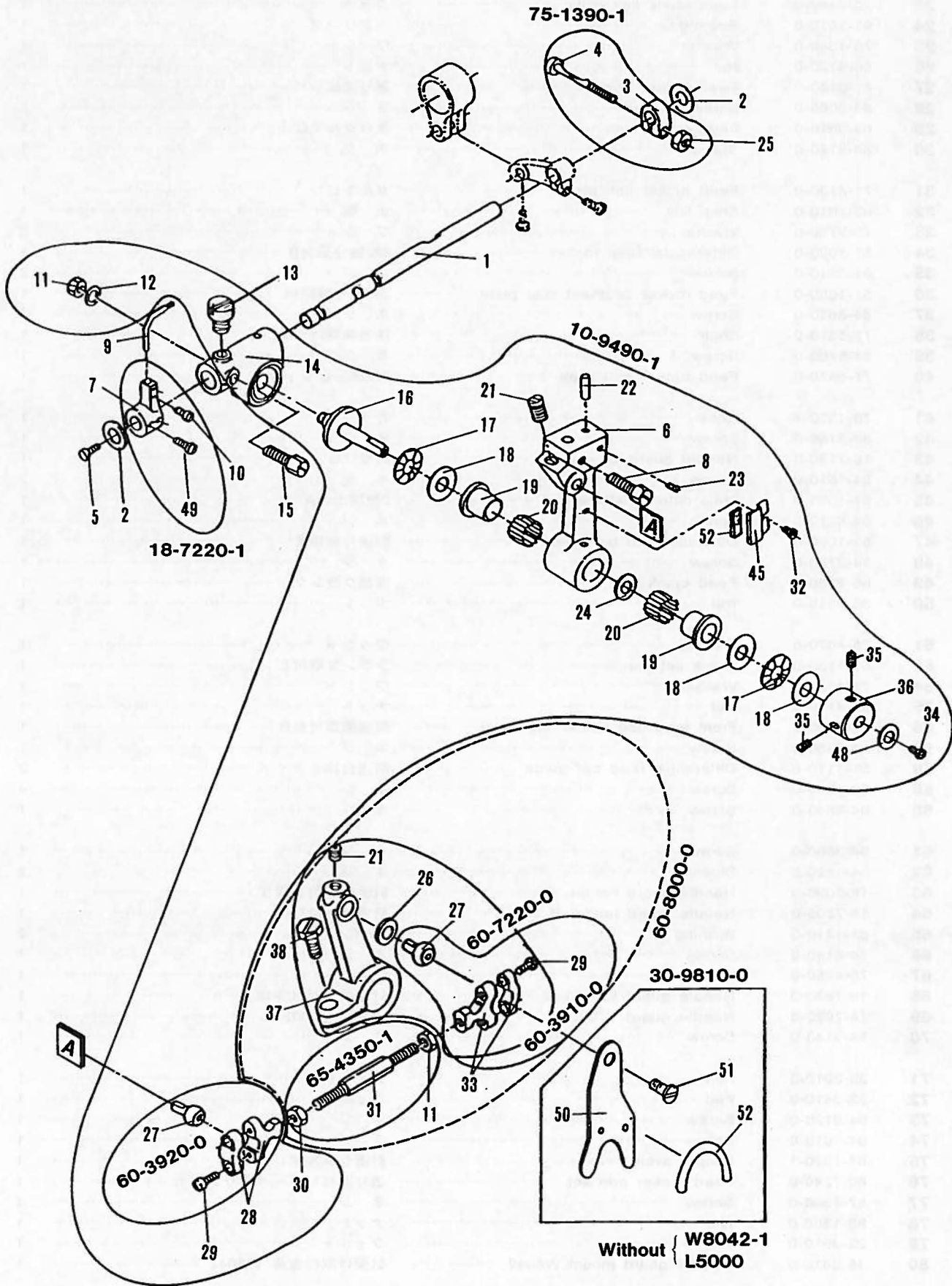

No.	Part No.	Part Name	品 名	Q, ty
1	71-5610-0	Looper holder shaft	ルーバー台シャフト	1
2	75-3720-0	Washer	ワッシャ	2
3	75-1390-1	Looper holder shaft collar	ルーバー台シャフト締めカラー	1
4	71-4540-0	Pin	締めカラー止ピン	1
5	84-7610-0	Screw	ネジ	1
6	19-3490-0	Looper holder	ルーバー台	1
7	18-7220-0	Needle bar guide bracket	針ガイドブラケットB	1
8	84-6160-0	Screw	ネジ	1
9	18-7250-0	Needle bar guide	針ガイドC	1
10	84-3620-0	Screw	ネジ	1
11	86-4110-0	Nut	ナット	2
12	75-4580-0	Washer	ワッシャ	1
13	84-7180-0	Screw	ネジ	1
14	19-3090-0	Looper rocker	ルーバー元台	1
15	84-7670-0	Screw	ネジ	1
16	71-8110-0	Shaft	ルーバー台軸受けシャフト	1
17	92-2300-0	Thrust bearing	スラストベアリング	2
18	75-4490-0	Washer	スラストワッシャ	3
19	81-8100-0	Bushing	ルーバー台ブッシュ	2
20	91-1060-0	Needle roller	ニードルローラー	32
21	84-7180-0	Screw	ネジ	1
22	71-2160-0	Pin	ピン	1
23	84-1120-0	Screw	ネジ	1
24	75-3700-0	Washer	スペースワッシャ	1
25	86-3140-0	Nut	ナット	1
26	75-4010-0	Washer	上飾りロッドワッシャ	1
27	61-5130-U	Connecting ball	ルーバー振元ロッド玉C	2
28	63-8120-1	Connecting rod (left)	連結ロッド (左)	1
29	84-5670-0	Screw	ネジ	4
30	86-4120-0	Nut (left)	ナット (左)	1
31	65-4350-0	Connecting bar	連結棒	1
32	84-1150-0	Screw	ネジ	1
33	63-8110-1	Connecting rod	連結ロッド	1
34	84-4010-0	Screw	ネジ	1
35	84-5210-0	Screw	ネジ	2
36	75-8110-0	Collar	スラストカラー	1
37	67-2290-1	Looper driving lever	ルーバー振元レバー	1
38	85-2100-0	Screw	ネジ	1
45	23-8100-0	Presser bracket	フェルト押え金具	1
48	75-4600-0	Washer	ワッシャ	1
49	84-8160-0	Screw	ネジ	1
50	39-8100-0	Oil fence	振元レバーオイルフェンス	1
51	84-1610-0	Screw	ネジ	1
52	23-3410-0	Felt	フェルト	2

# 10. Foot lifter components (押え揚げ機構)

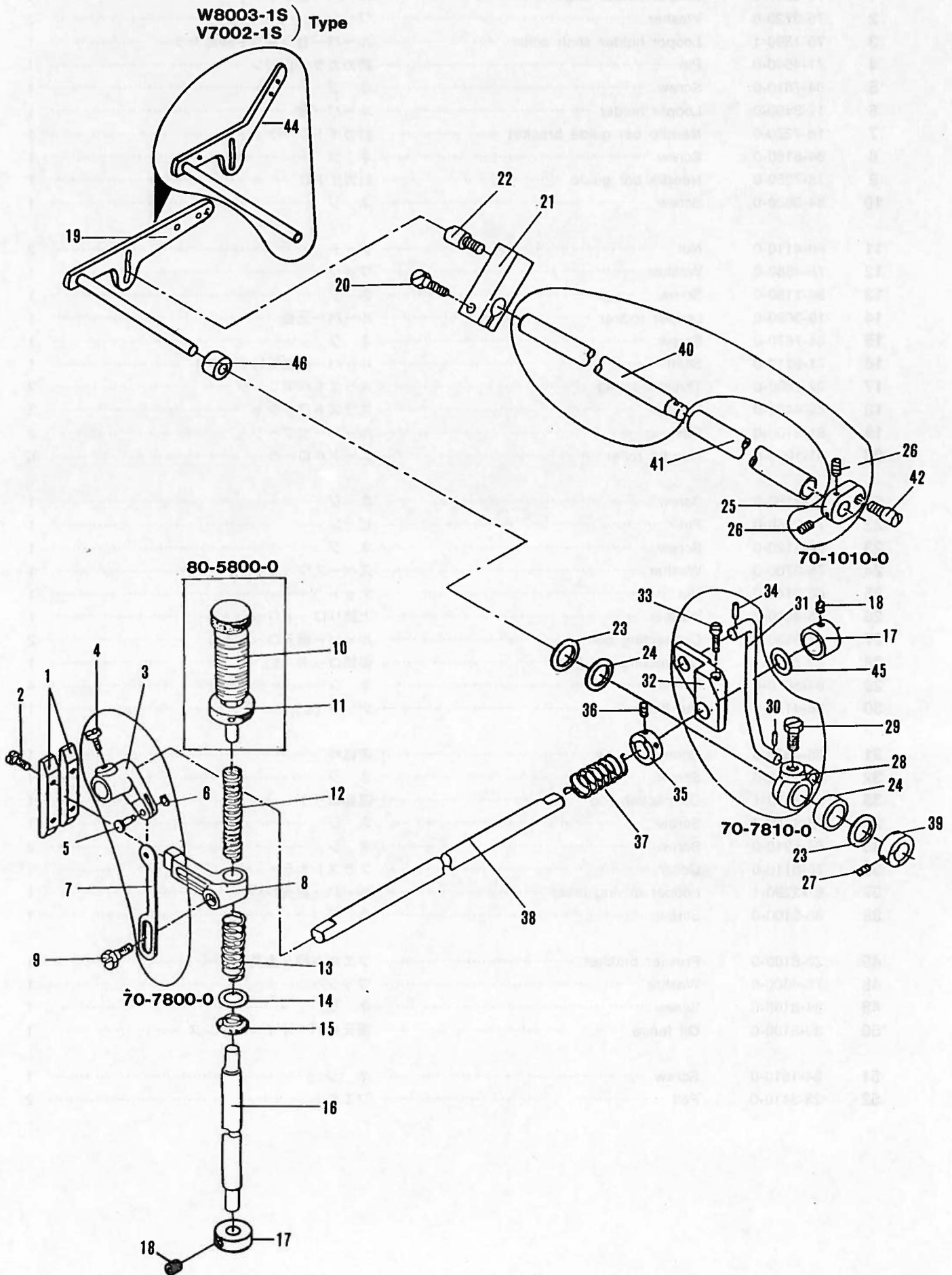

No.	Part No.	Part name	品 名	Q.ty
1	77-1390-0	Presser bar connecting guide D	押棒案内板 D	2
2	84-5670-0	Screw	ネ ジ	4
3	77-8020-0	Foot lifter crank	押え揚げクランク	1
4	84-8160-0	Screw	ネ ジ	1
5	71-3260-0	Pin	押揚げ連結ピン	1
6	93-2000-0	E-ring	E-リング	1
7	77-8010-0	Foot lifter connecting plate	押揚げ連結板	1
8	77-8030-1	Presser bar guide	押棒抱き	1
9	84-8170-0	Screw	ネ ジ	1
10	85-8010-0	Screw	ネ ジ	1
11	86-8510-0	Nut	ナット	1
12	79-1230-0	Presser bar spring	上軸押えバネ	1
13	79-0420-0	Oil seal spring	バ ネ	1
14	75-4360-0	Washer	ワッシャ	1
15	23-3110-0	Oil seal	押棒油止めシール	1
16	71-5430-0	Presser bar C	押棒 C	1
17	75-1540-1	Collar	カラー	2
18	84-5110-0	Screw	ネ ジ	2
19	77-8880-0	Control lever	押揚げコントロールレバー B	1
20	84-8120-0	Screw	ネ ジ	1
21	77-1030-0	Adjusting post supporter	調子芯棒止め板	1
22	84-5610-0	Screw	ネ ジ	1
23	75-3720-0	Washer	ワッシャ	2
24	94-8020-0	Oil seal	オイルシール	2
25	77-1010-0	Lifter lever connecting	丸 駒	1
26	84-5210-0	Screw	ネ ジ	2
27	84-6160-0	Screw	ネ ジ	1
28	77-8060-1	Lever A	押揚げ連結レバーA	1
29	85-2120-0	Screw	ネ ジ	1
30	93-6110-0	Pin	スナップピンA	1
31	77-8080-0	Connecting rod	押揚げ連結棒	1
32	77-8070-1	Lever B	押揚げ連結レバーB	1
33	84-7180-0	Screw	ネ ジ	1
34	93-6110-0	Pin	ピ ン	1
35	77-8150-0	Spring set collar	カラー	1
36	85-1130-0	Screw	ネ ジ	2
37	79-2270-0	Spring	バ ネ	1
38	71-5550-0	Foot lifter interlocking shaft	押揚げ連動シャフト	1
39	75-1300-1	Collar	カラー	1
40	77-1110-0	Crank shaft B	押揚げクランクシャフトB	1
41	77-1210-0	Crank shaft pipe	押揚げクランクシャフトパイプ	1
42	84-5620-0	Screw	ネ ジ	1
44	77-8130-0	Control lever (V7002-IS Type)	押揚げレバー (V7002-ISタイプ)	1
45	75-4510-0	Washer	ワッシャ	1
46	75-8880-0	Collar	押揚げスペースカラー	1

# 11. Spreader components (上飾り機構)

## W8000, W8042, W8042-1, W8004D-Type

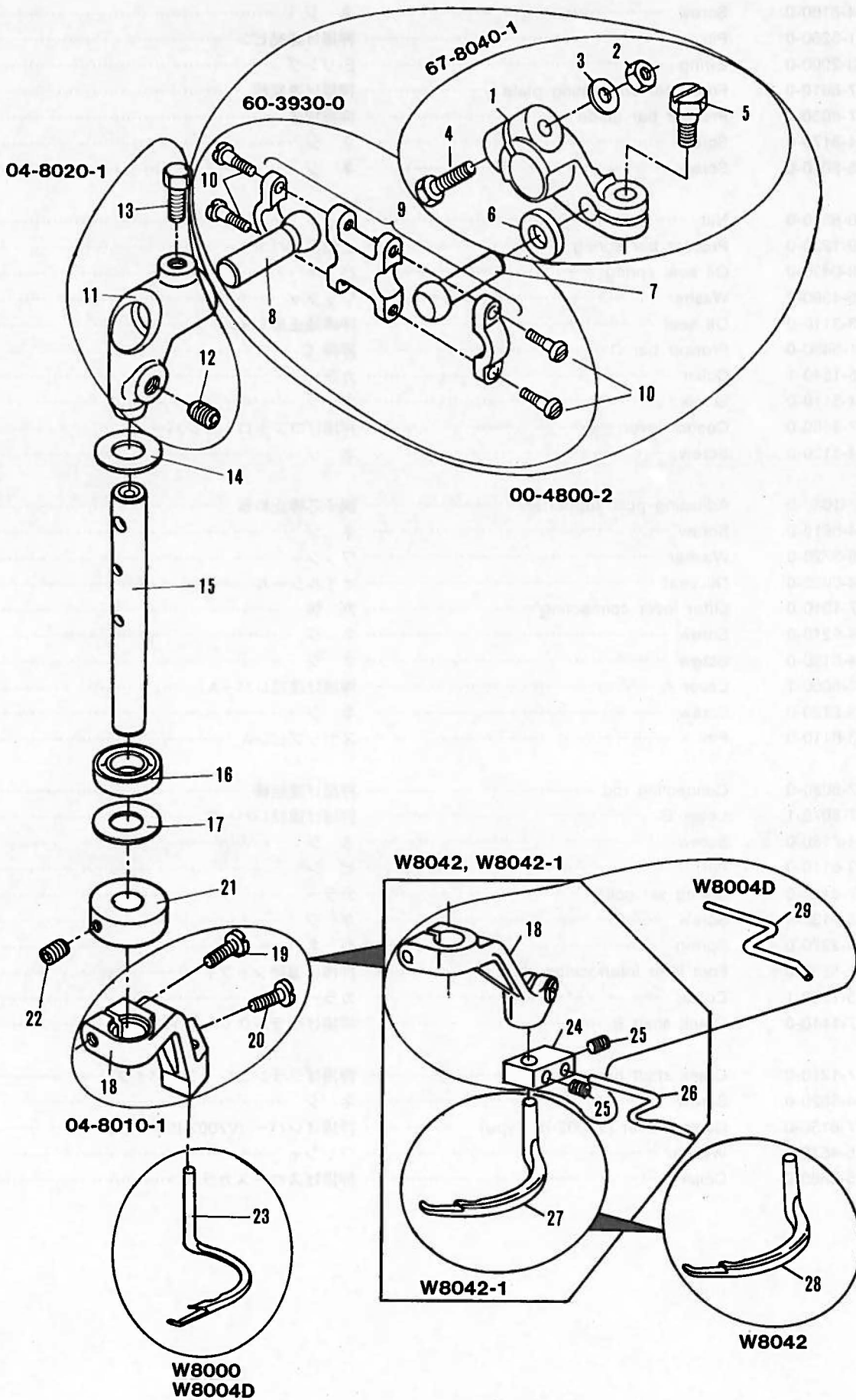

No.	Part No.	Part name	品 名	Q, ty
1	67-8040-0	Coverring lever .....	上飾り駆動レバー .....	1
2	86-5010-0	Nut .....	ナット .....	1
3	75-5520-0	Washer .....	ワッシャ .....	1
4	71-4550-0	Screw pin .....	立ロット連結レバー止メピン .....	1
5	84-4130-0	Screw .....	ネジ .....	1
6	75-3980-0	Washer .....	ワッシャ .....	1
7	61-8020-U	Connecting rod B .....	上飾り連結ロッド玉B .....	1
8	61-8010-U	Connecting rod A .....	上飾り連結ロッド玉A .....	1
9	63-5250-1	Connecting ball joint .....	上飾り連結ロッド .....	1
10	84-1720-0	Screw .....	ネジ .....	4
11	04-8020-0	Joint .....	上飾りジョイント .....	1
12	84-7260-0	Screw .....	ネジ .....	1
13	84-6110-0	Screw .....	ネジ .....	1
14	75-3560-0	Washer .....	ワッシャ .....	1
15	71-5530-0	Shaft .....	飾り土台シャフト .....	1
16	94-8010-0	Oil seal .....	オイルシール .....	1
17	75-1800-0	Washer .....	ワッシャ .....	1
18	04-8010-1	Looper crank .....	上飾りルーパークランク .....	1
19	84-5670-0	Screw .....	ネジ .....	1
20	84-3630-0	Screw .....	ネジ .....	1
21	75-1520-1	Collar .....	カラー .....	1
22	84-5110-0	Screw .....	ネジ .....	2
23	19-8070-0	Coverring looper .....	上飾りルーパー B .....	1
24	19-8440-0	Wire mount .....	補助金具 .....	1
25	84-1150-0	Screw .....	ネジ .....	2
26	19-8430-0	Guide wire .....	補助ガイド .....	1
27	19-8410-0	Covering looper W8042-1 .....	上飾りルーパー W8042-1 .....	1
28	19-8420-0	Covering looper W8042 .....	上飾りルーパー W8042 .....	1
29	19-8400-0	Guide wire W8004D .....	補助ガイド W8004D .....	1

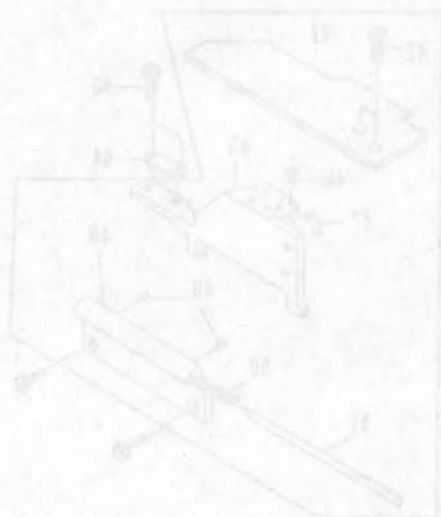

Subclass model (サブクラス機構)

12. Thread eyelet components (糸道機構) W8042, W8042-1-Type

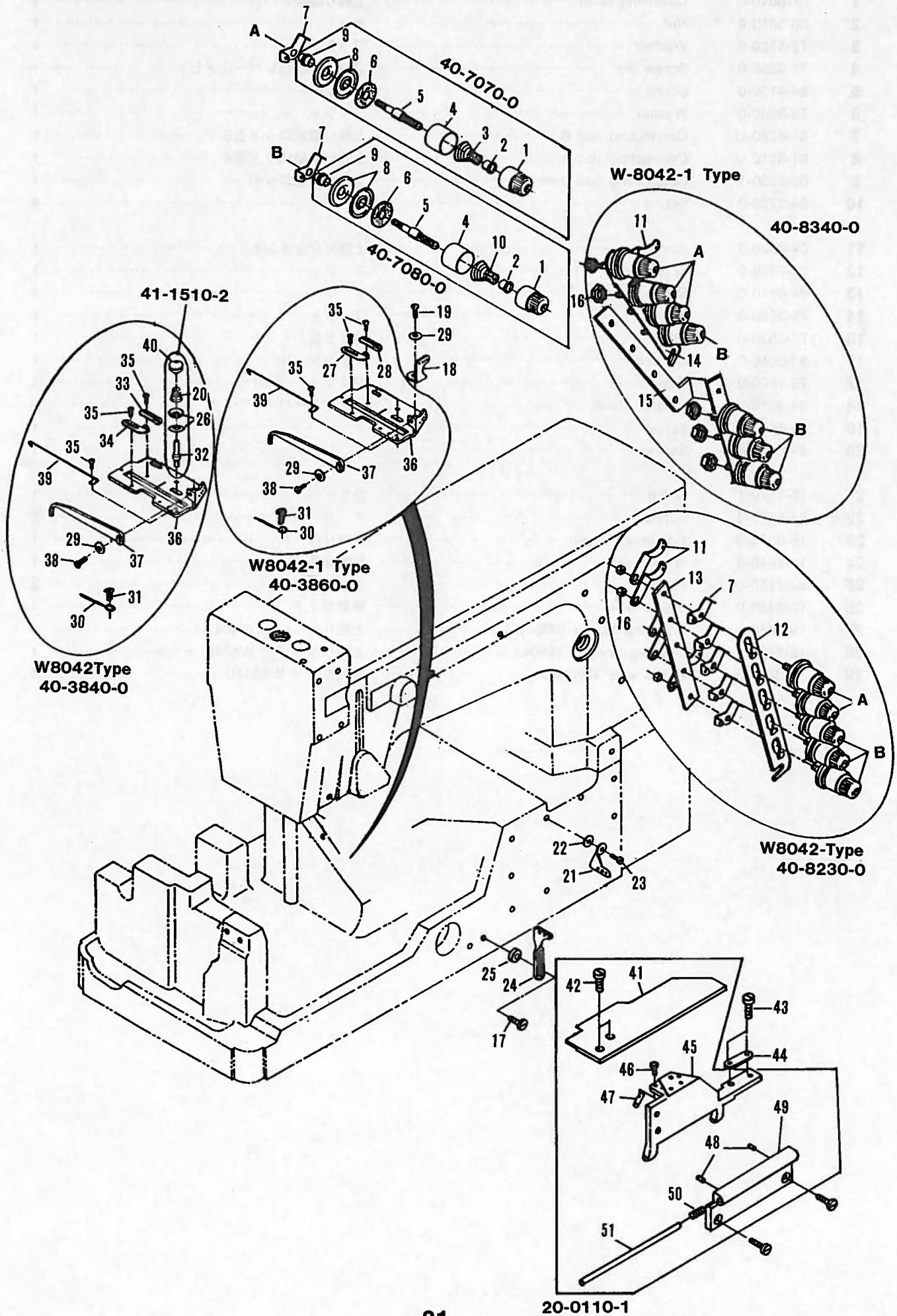

No.	Part No.	Part Name	品名	W8042	W8042-1
1	41-1010-0	Adjusting nut	チャンポン皿小ケース	5	7
2	41-1050-0	Adjusting ratchet	チャンポン皿ラチェット	5	7
3	41-7010-0	Spring (strong)	チャンポン調子バネ(強)	2	3
4	41-1070-0	Disc cover	チャンポン皿大ケース	5	7
5	41-1720-0	Tension post	調子棒(中)	5	7
6	23-3240-0	Felt	フェルト	5	7
7	41-1150-0	Thread eyelet	糸道上	5	7
8	41-1110-0	Disc	チャンポン皿	10	14
9	41-1310-0	Collar A	調子棒カラー(A)	5	7
10	41-7020-0	Spring (weak)	チャンポン調子バネ(弱)	3	4
11	41-1170-0	Thread eyelet	糸道下	5	7
12	41-236B-0	Tension post support	チャンポン皿調節板	1	
13	41-237B-0	Tension post holder	チャンポン元板	1	
14	41-113B-0	Tension post support	チャンポン調節板		1
15	41-123B-0	Tension post holder (large)	チャンポン調節元板(大)		1
16	86-4110-0	Nut	ナット	3	5
17	84-3610-0	Screw	ネジ	1	1
18	47-8410-0	Thread eyelet for cast-off support	下糸捌き取付糸道 (W8042-1)		1
19	84-6120-0	Screw	ネジ		1
20	41-1530-0	Spring	バネ	1	
21	47-1660-0	Looper thread eyelet	下糸糸道	1	
22	23-1870-0	O-ring	Oリング	1	1
23	84-5660-0	Screw	ネジ	1	1
24	45-1020-0	Needle thread eyelet 3	上糸糸道 (上)3	1	1
25	23-1870-0	O-ring	Oリング	1	1
26	41-1550-0	Tension nipper plate	捌き用小チャンポン皿	2	
27	47-1280-0	Looper thread guide eyelet (left)	下糸捌き板案内糸道(左)		1
28	47-1270-0	Looper thread guide eyelet (right)	下糸捌き板案内糸道(右)		1
29	75-4680-0	Washer	ワッシャ	1	2
30	43-1050-0	Guide pin	下糸捌きピン	1	1
31	84-5740-0	Screw	ネジ	1	1
32	41-1510-0	Looper thread guide tension stud	上糸チャンポン用調子棒	1	
33	47-1320-0	Looper thread guide eyelet (right)	下糸捌き板案内糸道(右)	1	
34	47-1310-0	Looper thread guide eyelet (left)	下糸捌き板案内糸道(左)	1	
35	84-1630-0	Screw	ネジ	3	3
36	43-3420-0	Cast-off support bracket	下糸捌き板	1	1
37	43-3440-0	Looper thread retainer upper	下糸捌き上	1	1
38	84-3610-0	Screw	ネジ	1	1
39	43-3380-0	Looper thread retainer pin	下糸捌き下ピン	1	1
40	41-1540-0	Nut	ナット	1	
41	21-1920-0	Ruller plate	定規板	1	1
42	84-5720-0	Screw	ネジ	2	2
43	85-1810-0	Screw	ネジ	2	2
44	26-7120-0	Folder base bracket	ラッパ取付台	1	1
45	21-1080-0	Ruller holder	定規台	1	1
46	84-4620-0	Screw	ネジ	1	1
47	71-4010-0	Ruller holder back spring	定規台裏バネピン	1	1
48	84-3140-0	Screw	ネジ	2	2
49	25-1080-0	Hinge	ヒンジ	1	1
50	79-2330-0	Spring	取付巻バネ	1	1
51	71-3080-0	Hinge pin	ヒンジピン	1	1



Subclass model (サブクラス機構)

### 13. Feed rocker and looper (送り, 及びルーパー機構) W8042-1-Type

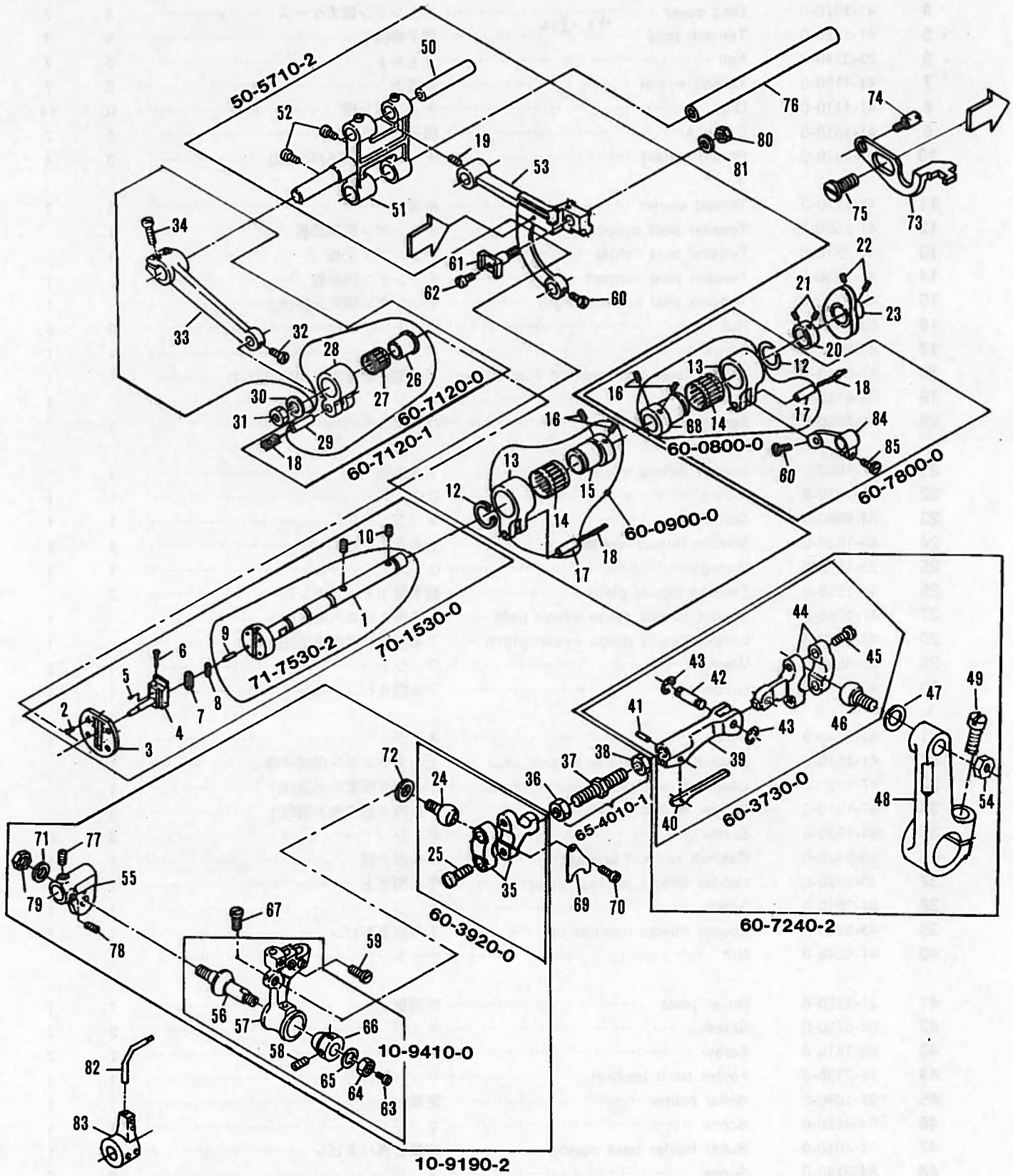

No.	Part No.	Part Name	品名	Q, ty
1	71-7530-0	Main shaft 5C	前下シャフト5C	1
2	84-6610-0	Screw	ネジ	4
3	51-0310-0	Head plate	メインシャフトヘッドプレート	1
4	51-0130-0	Feed crank adjusting post	送り調節芯棒	1
5	85-6240-0	Screw	ネジ	1
6	84-3830-0	Screw	ネジ	1
7	23-1970-0	O-ring	Oリング	1
8	51-0360-0	Oil guard	オイルガード	1
9	23-3930-0	Felt	フェルト	1
10	23-3410-0	Felt	フェルト	1
12	93-4060-0	Snap ring	スナップリング	2
13	63-2320-U	Feed eccentric link B	エキセンダルマ (B)	2
14	91-4060-0	Bearing	ベアリング	2
15	61-3220-0	Feed eccentric 0.9	針返しエキセン玉	1
16	84-5210-0	Screw	ネジ	4
17	71-4310-0	Connecting link pin	ダルマピン	2
18	23-3410-0	Felt	フェルト	3
19	84-7120-0	Screw	ネジ	1
20	75-1140-1	Collar	ハマグリカラー	1
21	84-5110-0	Screw	ネジ	2
22	84-7110-0	Screw	ネジ	2
23	49-1420-1	Looper thread double disc take up	ハマグリ	1
24	61-5130-U	Connecting ball	ルーバー振り元ロッド玉	1
25	84-5670-0	Screw	ネジ	2
26	75-2430-0	Feed crank link roller C	送りダルマローラー C	1
27	91-2710-0	Bearing	ベアリング	1
28	63-3530-2	Feed rocker link	送りダルマ	1
29	71-4320-0	Feed rocker link pin	メガネピン	1
30	75-4530-0	Washer	ワッシャ	1
31	86-4120-0	Nut	ナット	1
32	84-3660-0	Screw	ネジ	1
33	67-3110-1	Feed rocker arm A	送り連結レバーA	1
34	84-6120-0	Screw	ネジ	2
35	63-8120-1	Connecting rod	連結ロッド (左)	1
36	86-4120-0	Nut	ナット	1
37	65-4010-0	Connecting bar	連結棒 (大)	1
38	86-4110-0	Nut	ナット	1
39	65-9020-0	Looper driving connecting link	ルーバー折り曲げダルマ金具	1
40	79-6010-0	Plate spring	折り曲げロッド用板バネ	1
41	71-2010-0	Pin	ノックピン	1
42	71-3220-0	Pin	折り曲げダルマピン	1
43	93-2010-0	Stop ring	ストップリング	2
44	63-8210-U	Connecting rod	ルーバー折り曲げロッド	1
45	84-5720-0	Screw	ネジ	2
46	61-8230-U	Connecting ball	ルーバー連結ロッド玉	1
47	75-4010-0	Washer	ワッシャ	1
48	67-2420-1	Looper driving lever C	ルーバー振り元レバー	1
49	85-2100-0	Screw	ネジ	1
50	71-5310-0	Feed rocker arm shaft	後送り歯取付台シャフト	1
51	55-0410-0	Single feed rocker arm	1枚送り元台	1
52	84-5210-0	Screw	ネジ	2
53	55-1760-0	Feed rocker	送り土台	1
54	86-4110-0	Nut	ナット	1
55	19-3050-0	Looper rocker	ルーバー元台	1
56	71-9010-0	Looper rocker tapered pin	ルーバー台テーパピン	1
57	19-3410-0	Looper holder	ルーバー台	1
58	84-5210-0	Screw	ネジ	2
59	84-6160-0	Screw	ネジ	3
60	84-3660-0	Screw	ネジ	2
61	55-0510-0	Feed dog holder	送り歯取付台	1
62	84-5880-0	Screw	ネジ	1
63	84-3610-0	Screw	ネジ	1
64	86-5010-0	Nut	ナット	1
65	75-4520-0	Washer	ワッシャ(中)	1
66	81-4010-1	Tapered pin bushing	テーパピン押しブッシュ	1
67	84-7180-0	Screw	ネジ	1
68	61-3120-0	Feed eccentric 0.79	針返しエキセン玉 0.79	1
69	35-1990-0	Gaude fork	ルーバー台用オイル案内板	1
70	84-1610-0	Screw	ネジ	1
71	75-3810-0	Washer	ワッシャ	1
72	75-4530-0	Washer	ワッシャ	1
73	18-8400-0	Needle guard	針受け	1
74	84-1130-0	Screw	ネジ	1
75	84-3680-0	Screw	ネジ	1
76	71-6420-0	Feed rocker arm shaft	送り元台シャフト	1
77	84-7660-0	Screw	ネジ	1
78	84-7670-0	Screw	ネジ	1
79	86-5020-0	Nut	ナット	1
80	86-5010-0	Nut	ナット	1
81	75-3810-0	Washer	ワッシャ	1
82	18-7250-0	Front needle bar guide	前針ガイド	1
83	18-7220-0	Needle bar guide bracket A	針ガイドブラケット	1
84	67-1320-1	Looper avoid lever	針返しダルマレバー	1
85	84-6120-0	Screw	ネジ	1

Subclass model (サブクラス機構)

14. Feed rocker and looper (送り, 及びルーパー機構) W8042-Type

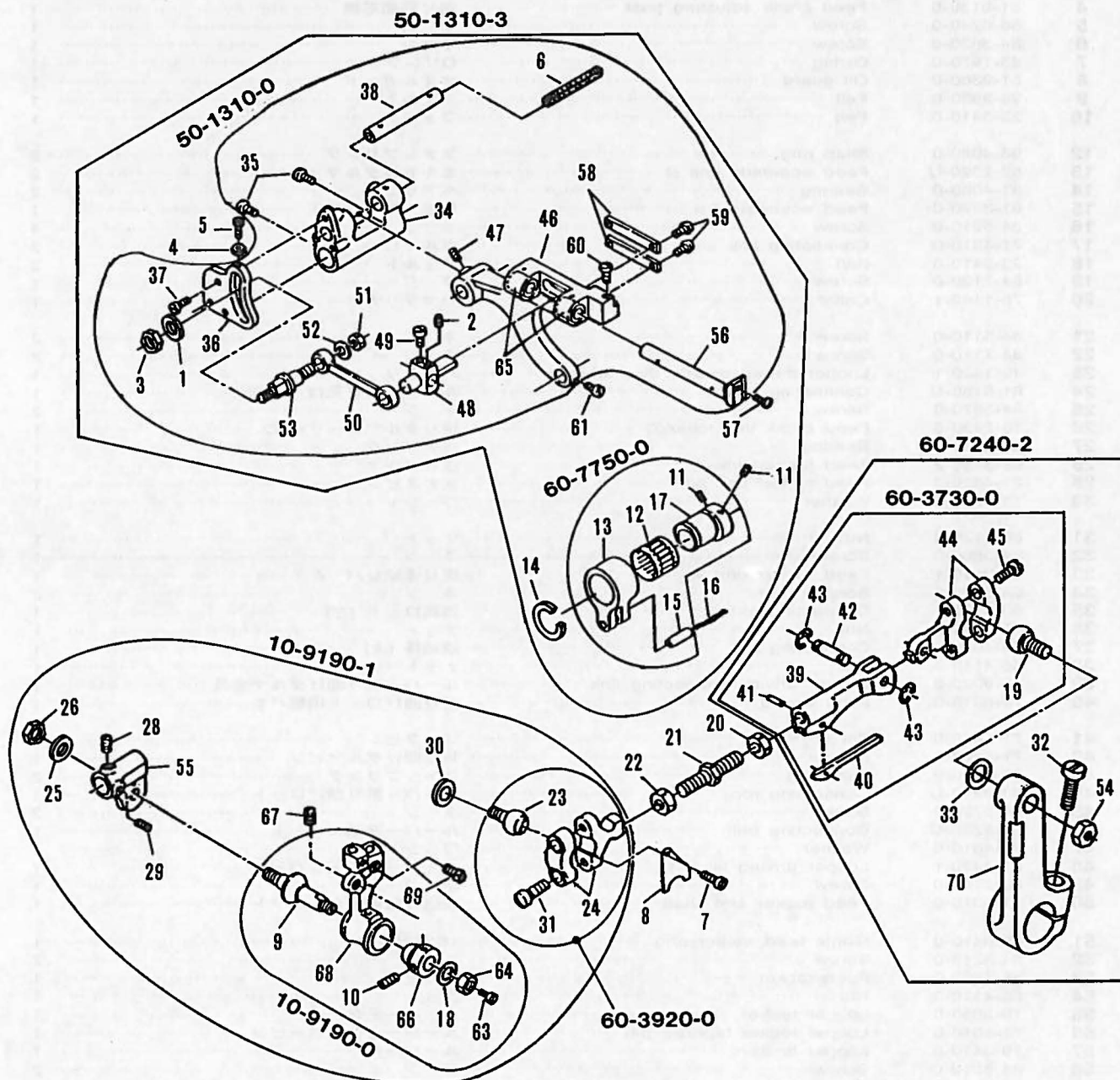

No.	Part No.	Part Name	品名	Q, ty
1	75-4670-0	Washer	ワッシャ	1
2	84-3140-0	Screw	ネジ	1
3	86-4110-0	Nut	ナット	1
4	88-1360-0	Nut	ナット	1
5	87-1360-0	Screw	ネジ	1
6	23-3910-0	Felt	フェルト	1
7	84-1640-0	Screw	ネジ	1
8	35-1990-0	Gaude fork	ルーパー台用オイル案内板	1
9	71-9010-0	Looper rocker tapered pin	ルーパー台テーパーピン	1
10	84-5210-0	Screw	ネジ	2
11	84-5210-0	Screw	ネジ	2
12	91-4060-0	Bearing	エキセンダルマ	1
13	63-2320-U	Eccentric link	エキセンダルマ	1
14	93-4060-0	Snap ring	サークリップ	1
15	71-4310-0	Connecting link pin	ダルマピン	1

No.	Part No.	Part Name	品 名	Q, ty
16	23-3410-0	Felt	フェルト	1
17	61-3140-0	Looper avoid eccentric	針返しエキセン玉	1
18	75-4520-0	Washer	ワッシャ	1
19	61-8230-U	Connecting ball	ルーバー連絡ロッド玉	1
20	86-4110-0	Nut	ナット	1
21	65-4010-1	Connecting bar	連結棒 (大)	1
22	86-4120-0	Nut	ナット	1
23	61-5130-U	Connecting ball	ルーバー振り元ロッド玉	1
24	63-8120-1	Connecting rod	連結ロッド(左)	1
25	75-3810-0	Washer	ワッシャ	1
26	86-5020-0	Nut	ナット	1
28	84-7670-0	Screw	ネジ	1
29	84-7660-0	Screw	ネジ	1
30	75-4530-0	Washer	ワッシャ	1
31	84-5670-0	Screw	ネジ	2
32	85-2100-0	Screw	ネジ	1
33	75-4010-0	Washer	ワッシャ	1
34	51-1020-0	Differential feed rocker	2枚送り元台 (B)	1
35	84-5210-0	Screw	ネジ	2
36	51-1050-0	Feed rocker segment slot plate	2枚送り調節板	1
37	84-3630-0	Screw	ネジ	3
38	71-5310-0	Shaft	後送り歯取付台シャフト	1
39	65-9020-0	Looper driving connecting link	ルーバー折り曲げダルマ金具	1
40	79-6010-0	Plate spring	折り曲げロッド用板バネ	1
41	71-2010-0	Pin	ノックピン	1
42	71-3220-0	Pin	ピン	1
43	93-2010-0	Stop ring	ストップリング	2
44	63-8210-U	Connecting rod	ルーバー折り曲げロッド	1
45	84-5720-0	Screw	ネジ	2
46	51-1030-0	Main differential feed	2枚送土台 (A)	1
47	84-5210-0	Screw	ネジ	1
48	51-1090-0	Differential feed bar guide	前送り台抱き	1
49	84-3790-0	Screw	ネジ	1
50	66-5060-0	Feed crank link	連結クランク	1
51	86-3110-0	Nut	ナット	1
52	75-4580-0	Washer	ワッシャ	1
53	51-1130-0	Crank set pin	クランク取付ピン	1
54	86-4110-0	Nut	ナット	1
55	19-3050-0	Looper rocker	ルーバー元台	1
56	51-1200-0	Front feed dog holder bracket	前送り歯取付台 (B)	1
57	84-3630-0	Screw	ネジ	1
58	51-1110-0	Differential feed bar guide	前送り台抱きガイド	2
59	84-1640-0	Screw	ネジ	4
60	84-4640-0	Screw	ネジ	1
61	84-3660-0	Screw	ネジ	1
63	84-3610-0	Screw	ネジ	1
64	86-5010-0	Nut	ナット	1
65	81-1410-0	Bushing	ブッシュ	2
66	81-4010-1	Tapered pin bushing	テーパピン押しブッシュ	1
67	84-7180-0	Screw	ネジ	1
68	19-3230-0	Looper holder	ルーバー台	1
69	84-6160-0	Screw	ネジ	2
70	67-2420-1	Looper driving lever	ルーバー振り元レバー	1

Subclass model (サブクラス機構)

15. Feed rocker and looper (送り及びルーパー機構) L5001-Type

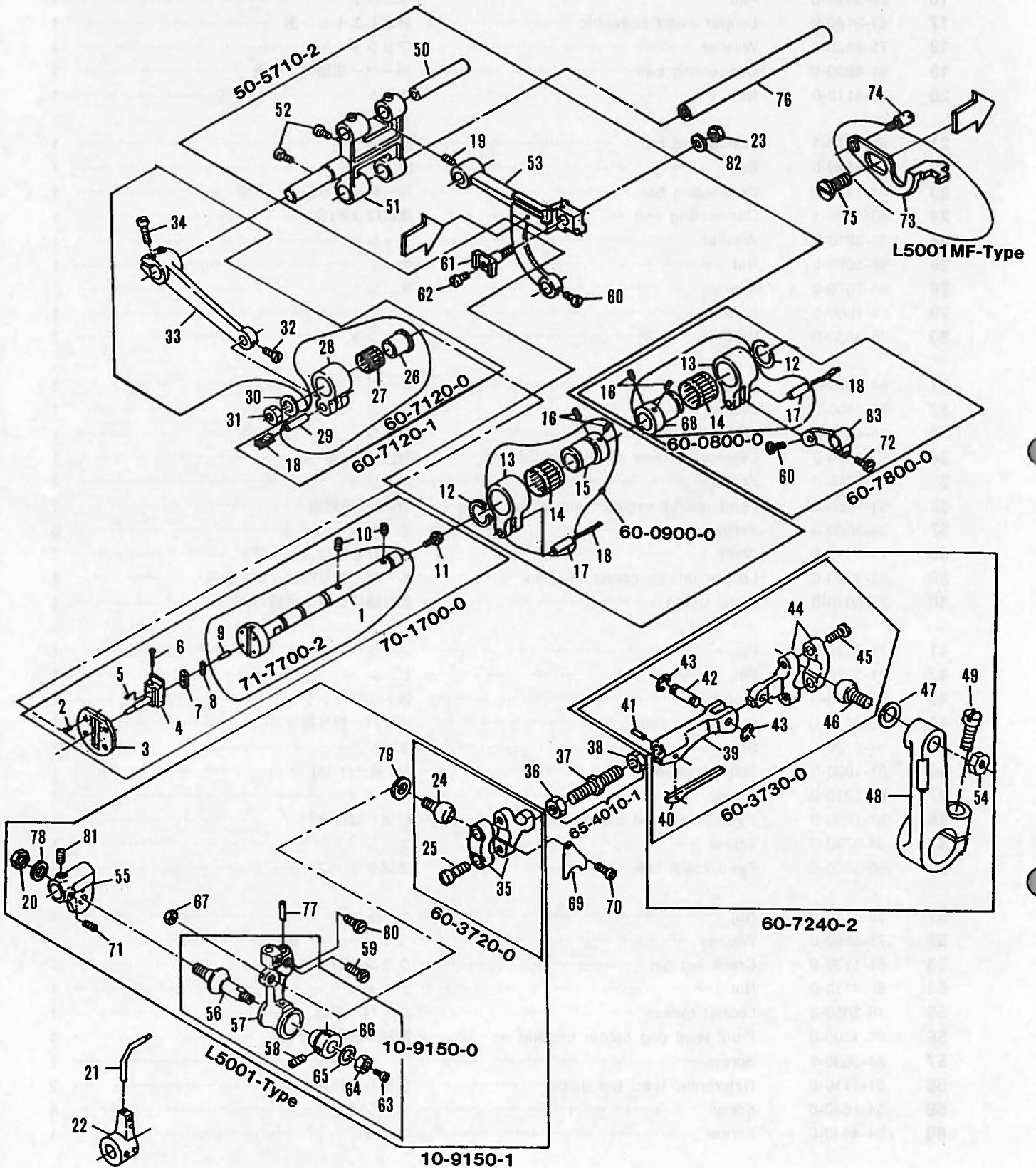

No.	Part No.	Part Name	品名	Q, ty
1	71-7700-0	Main shaft 5C	前下シャフト5C	1
2	84-6610-0	Screw	ネジ	4
3	51-0310-0	Head plate	メインシャフトヘッドプレート	1
4	51-0130-0	Feed crank adjusting post	送り調節芯棒	1
5	85-6240-0	Screw	ネジ	1
6	84-3830-0	Screw	ネジ	1
7	23-1970-0	O-ring	リング	1
8	51-0360-0	Oil guard	オイルガード	1

No.	Part No.	Part Name	品名	Q, ty
9	23-3930-0	Felt	フェルト	1
10	23-3410-0	Felt	フェルト	1
11	84-5760-0	Screw	ネジ	1
12	93-4060-0	Snap ring	スナップリング	2
13	63-2320-U	Feed eccentric link B	エキセンダルマ (B)	2
14	91-4060-0	Bearing	ベアリング	2
15	61-3220-0	Feed eccentric 0.9	針返しエキセン玉	1
16	84-5210-0	Screw	ネジ	4
17	71-4310-0	Connecting link pin	ダルマピン	2
18	23-3410-0	Felt	フェルト	3
19	84-7120-0	Screw	ネジ	1
20	86-5020-0	Nut	ナット	1
21	18-7250-0	Front needle bar guide	前針ガイド	1
22	18-7220-0	Needle bar guide bracket A	針ガイドブラケットA	1
23	86-5010-0	Nut	ナット	1
24	61-8230-U	Connecting ball	ルーバー振り元ロット玉	1
25	84-5670-0	Screw	ネジ	2
26	75-2430-0	Feed crank link role C	送りダルマローラ (C)	1
27	91-2710-0	Bearing	ベアリング	1
28	63-3530-2	Feed rocker link	送りダルマ	1
29	71-4320-0	Feed rocker link pin	メガネピン	1
30	75-4530-0	Washer	ワッシャ	1
31	86-4120-0	Nut	ナット	1
32	84-3660-0	Screw	ネジ	1
33	67-3110-1	Feed rocker arm A	送り連結レバー (A)	1
34	84-6120-0	Screw	ネジ	2
35	63-8120-1	Connecting rod	連結ロット (左)	1
36	86-4120-0	Nut	ナット	1
37	65-4010-1	Connecting bar	連結棒 (大)	1
38	86-4110-0	Nut	ナット	1
39	65-9020-0	Looper driving connecting link	ルーバー折り曲げダルマ金具	1
40	79-6010-0	Plate spring	折り曲げロット用板バネ	1
41	71-2010-0	Pin	ロックピン	1
42	71-3220-0	Pin	折り曲げダルマピン	1
43	93-2010-0	Stop ring	ストップリング	2
44	63-8210-U	Connecting rod	ルーバー折り曲げロット	1
45	84-5720-0	Screw	ネジ	2
46	61-8230-U	Connecting ball	ルーバー連結ロット玉	1
47	75-4010-0	Washer	ワッシャ	1
48	67-2420-1	Looper driving lever C	ルーバー振り元レバー	1
49	85-2100-0	Screw	ネジ	1
50	71-5310-0	Feed rocker arm shaft	後送り歯取付台シャフト	1
51	55-0410-0	Single feed rocker arm	1枚送り元台	1
52	84-5210-0	Screw	ネジ	2
53	55-1760-0	Feed rocker	送り土台	1
54	86-4110-0	Nut	ナット	1
55	19-3030-0	Looper rocker	ルーバー元台	1
56	71-9010-0	Looper rocker tapered pin	ルーバー台テーパピン	1
57	19-3150-0	Looper holder	ルーバー台	1
58	84-5210-0	Screw	ネジ	2
59	84-6160-0	Screw	ネジ	1
60	84-3660-0	Screw	ネジ	2
61	55-0510-0	Feed dog holder	送り歯取付台	1
62	84-5880-0	Screw	ネジ	1
63	84-3610-0	Screw	ネジ	1
64	86-5010-0	Nut	ナット	1
65	75-4520-0	Washer	ワッシャ (中)	1
66	81-4010-1	Tapered pin bushing	テーパピン押しブッシュ	1
67	86-4130-0	Nut	ナット	1
68	61-3120-0	Feed eccenuric 0.79	針返しエキセン玉 (0.79)	1
69	35-1990-0	Gaude fork	ルーバー台用オイル案内板	1
70	84-1610-0	Screw	ネジ	1
71	84-7670-0	Screw	ネジ	1
72	84-6120-0	Screw	ネジ	1
73	18-5010-0	Needle guard	針受け	1
74	84-1130-0	Screw	ネジ	1
75	84-3680-0	Screw	ネジ	1
76	71-6420-0	Feed rocker arm shaft	送り元台シャフト	1
77	71-2160-0	Pin	ピン	1
78	75-3810-0	Washer	ワッシャ	1
79	75-4530-0	Washer	ワッシャ	1
80	84-1610-0	Screw	ネジ	1
81	84-7660-0	Screw	ネジ	1
82	75-3810-0	Washer	ワッシャ	1
83	67-1320-1	Looper avoid lever	針返しダルマレバー	1

Subclass model (サブクラス機構)

16. Feed rocker and looper (送り, 及びルーパー機構) L5002TMF-Type

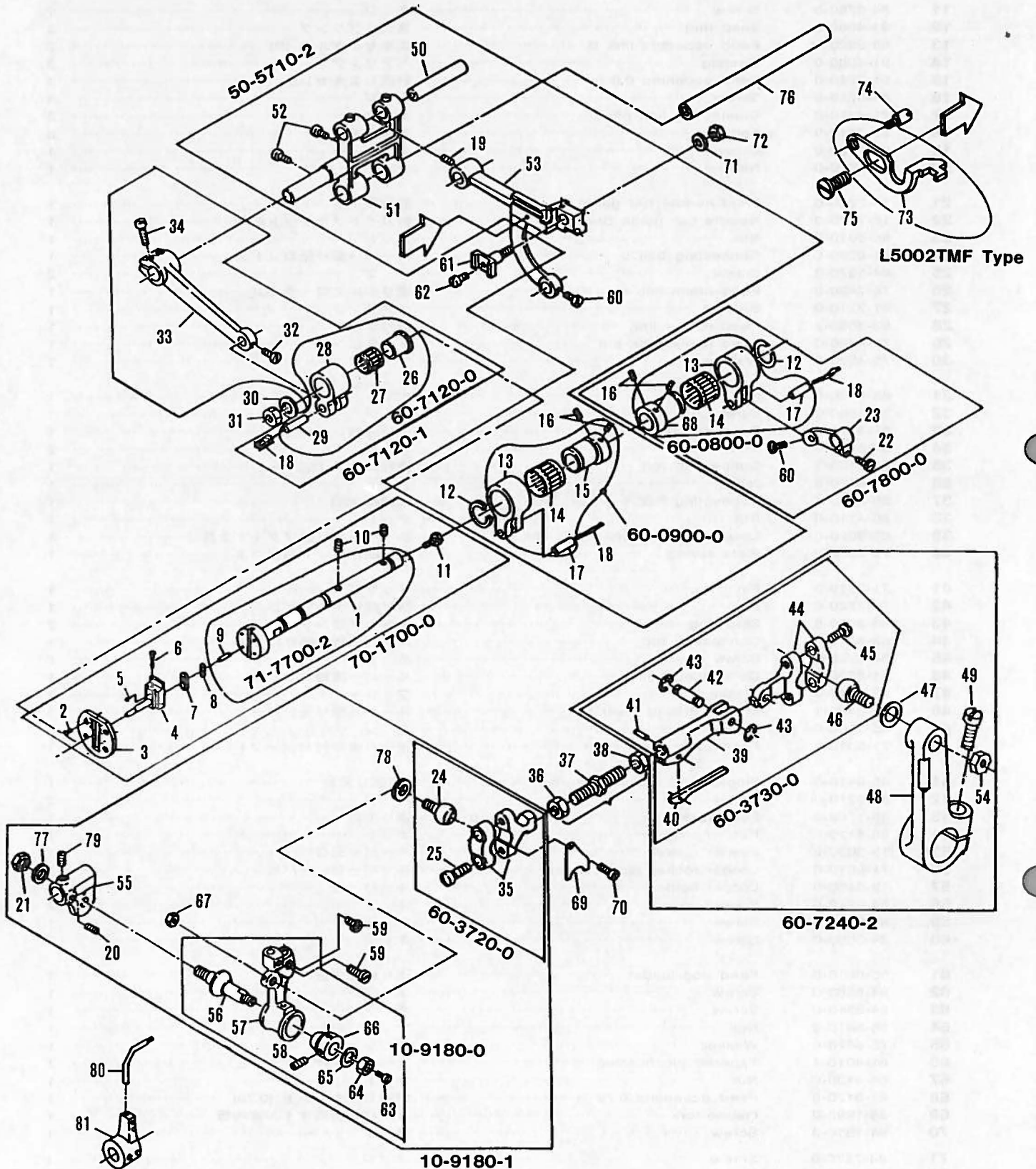

No.	Part No.	Part Name	品 名	Q, ty
1	71-7700-0	Main shaft 5C	前下シャフト5C	1
2	84-6610-0	Screw	ネジ	4
3	51-0310-0	Head plate	メインシャフトヘッドプレート	1
4	51-0130-0	Feed crank adjusting post	送り調節芯棒	1
5	85-6240-0	Screw	ネジ	1
6	84-3830-0	Screw	ネジ	1
7	23-1970-0	O-ring	リング	1
8	51-0360-0	Oil guard	オイルガード	1

No.	Part No.	Part Name	品名	Q, ty
9	23-3930-0	Felt	フェルト	1
10	23-3410-0	Felt	フェルト	1
11	84-5760-0	Screw	ネジ	1
12	93-4060-0	Snap ring	スナップリング	2
13	63-2320-U	Feed eccentric link B	エキセンダルマ (B)	2
14	91-4060-0	Bearing	ベアリング	2
15	61-3220-0	Feed eccentric 0.9	針返しエキセン玉	1
16	84-5210-0	Screw	ネジ	4
17	71-4310-0	Connecting link pin	ダルマピン	2
18	23-3410-0	Felt	フェルト	3
19	84-7120-0	Screw	ネジ	1
20	84-7670-0	Screw	ネジ	1
21	86-5020-0	Nut	ナット	1
22	84-6120-0	Screw	ネジ	1
23	67-1320-1	Looper avoid lever	針返しダルマレバー	1
24	61-8230-U	Connecting ball	ルーバー振り元ロット玉	1
25	84-5670-0	Screw	ネジ	2
26	75-2430-0	Feed crank link roller C	送りダルマローラ (C)	1
27	91-2710-0	Bearing	ベアリング	1
28	63-3530-2	Feed rocker link	送りダルマ	1
29	71-4320-0	Feed rocker link pin	メガネピン	1
30	75-4530-0	Washer	ワッシャ	1
31	86-4120-0	Nut	ナット	1
32	84-3660-0	Screw	ネジ	1
33	67-3110-1	Feed rocker arm A	送り連結レバー (A)	1
34	84-6120-0	Screw	ネジ	2
35	63-8120-1	Connecting rod	連結ロット (左)	1
36	86-4120-0	Nut	ナット	1
37	65-4010-1	Connecting bar	連結棒 (大)	1
38	86-4110-0	Nut	ナット	1
39	65-9020-0	Looper driving connecting link	ルーバー折り曲げダルマ金具	1
40	79-6010-0	Plate spring	折り曲げロット用板バネ	1
41	71-2010-0	Pin	ノックピン	1
42	71-3220-0	Pin	折り曲げダルマピン	1
43	93-2010-0	Stop ring	ストップリング	2
44	63-8210-U	Connecting rod	ルーバー折り曲げロット	1
45	84-5720-0	Screw	ネジ	2
46	61-8230-U	Connecting ball	ルーバー連結ロット玉	1
47	75-4010-0	Washer	ワッシャ	1
48	67-2420-1	Looper driving lever C	ルーバー振り元レバー	1
49	85-2100-0	Screw	ネジ	1
50	71-5310-0	Feed rocker arm shaft	後送り歯取付台シャフト	1
51	55-0410-0	Single feed rocker arm	1枚送り元台	1
52	84-5210-0	Screw	ネジ	2
53	55-1760-0	Feed rocker	送り土台	1
54	86-4110-0	Nut	ナット	1
55	19-3050-0	Looper rocker	ルーバー元台	1
56	71-9010-0	Looper rocker tapered pin	ルーバー台テーパピン	1
57	19-3180-0	Looper holder	ルーバー台	1
58	84-5210-0	Screw	ネジ	2
59	84-6160-0	Screw	ネジ	2
60	84-3660-0	Screw	ネジ	2
61	55-0510-0	Feed dog holder	送り歯取付台	1
62	84-5880-0	Screw	ネジ	1
63	84-3610-0	Screw	ネジ	1
64	86-5010-0	Nut	ナット	1
65	75-4520-0	Washer	ワッシャ (中)	1
66	81-4010-1	Tapered pin bushing	テーパピン押しブッシュ	1
67	86-4130-0	Nut	ナット	1
68	61-3120-0	Feed eccentric 0.79	針返しエキセン玉 (0.79)	1
69	35-1990-0	Gaude fork	ルーバー台用オイル案内板	1
70	84-1610-0	Screw	ネジ	1
71	75-3810-0	Washer	ワッシャ	1
72	86-5010-0	Nut	ナット	1
73	18-5270-0	Needle guard	針受け	1
74	84-1130-0	Screw	ネジ	1
75	84-3680-0	Screw	ネジ	1
76	71-6420-0	Feed rocker arm shaft	送り元台シャフト	1
77	75-3810-0	Washer	ワッシャ	1
78	75-4530-0	Washer	ワッシャ	1
79	84-7660-0	Screw	ネジ	1
80	18-7250-0	Front needle bar guide	前針ガイド	1
81	18-7220-1	Needle bar guide bracket A	針ガイドブラケットA	1



**17. Organization parts (サブクラス構成部品) L5001M, L5001MF -Type**  
**Ruller plate components (定規台関係)**

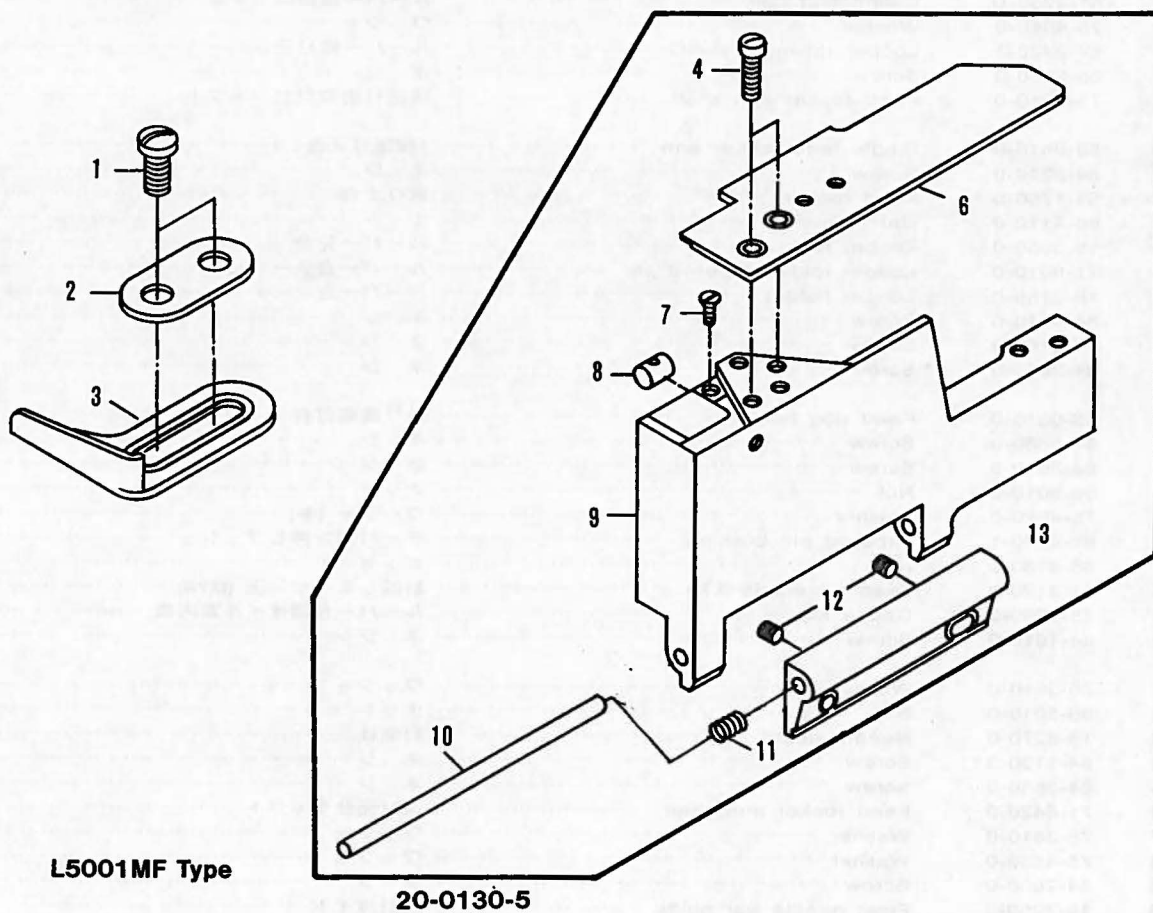
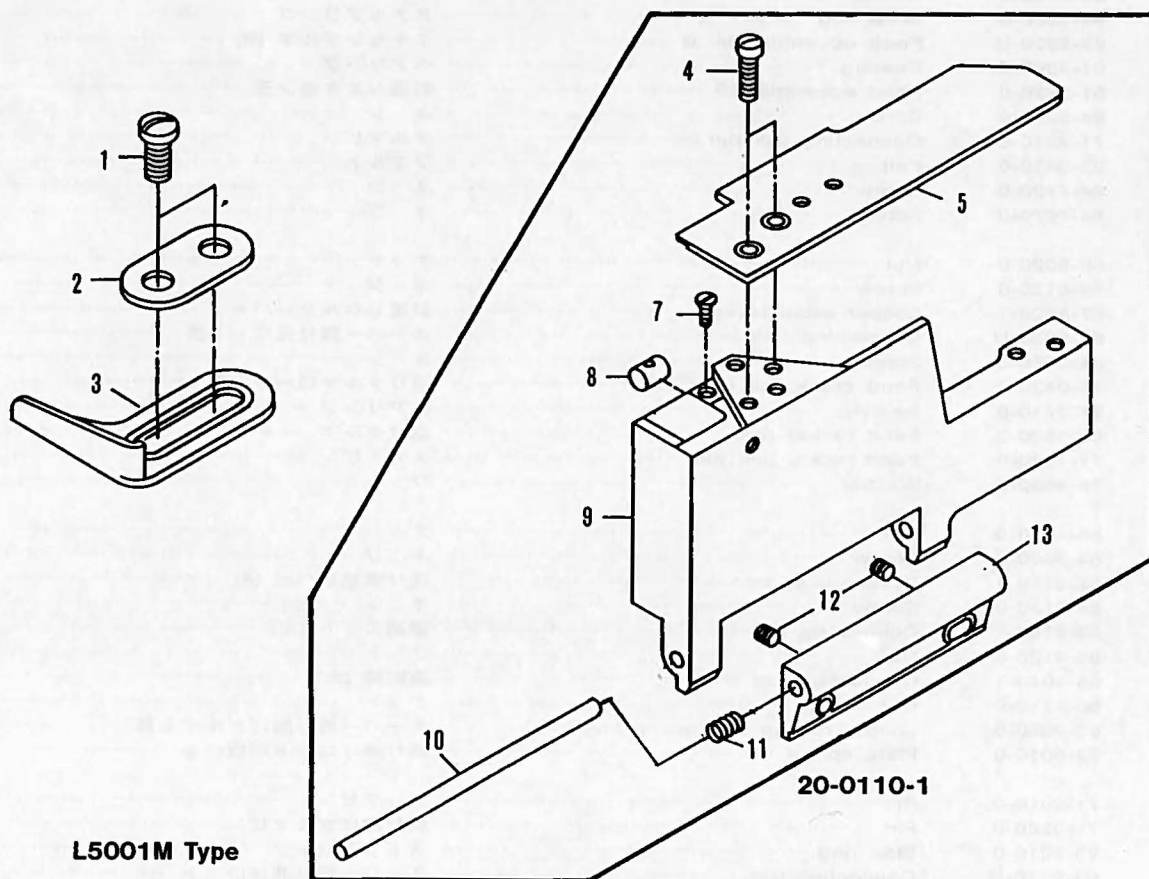

No.	Part No.	Part Name	品 名	L5001M	L5001MF
1	85-1810-0	Screw .....	ネ ジ .....	2	2
2	26-7120-0	Folder base bracket .....	ラッパ取付台 .....	1	1
3	26-5520-0	Guide .....	ガイド定規 .....	1	1
4	84-5720-0	Screw .....	ネ ジ .....	2	2
5	21-1920-0	Ruller plate A .....	定規板 .....	1	
6	21-1940-0	Ruller plate .....	定規板 .....		1
7	84-4620-0	Screw .....	ネ ジ .....	1	1
8	71-4010-0	Setting pin for ruller holder spring .....	定規台裏バネピン .....	1	1
9	21-1080-0	Ruller holder .....	定規台 .....	1	1
10	71-3080-0	Hinge pin .....	ヒンジピン .....	1	1
11	79-2330-0	Spring .....	取付巻バネ .....	1	1
12	84-3140-0	Screw .....	ネ ジ .....	2	2
13	25-1080-0	Hinge .....	定規台取付ヒンジ .....	1	1

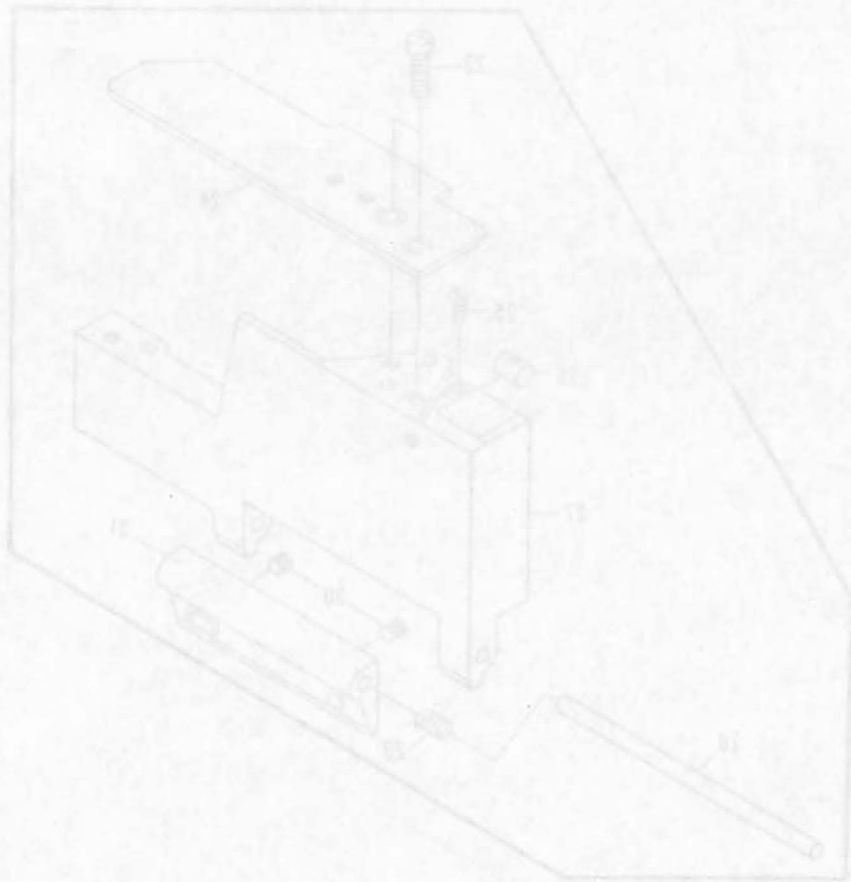

**18. Organization parts (サブクラス構成部品) L5002-TMF-Type**  
**Looper thread eyelet and Ruller plate components**  
 (下糸道及び定規台関係)

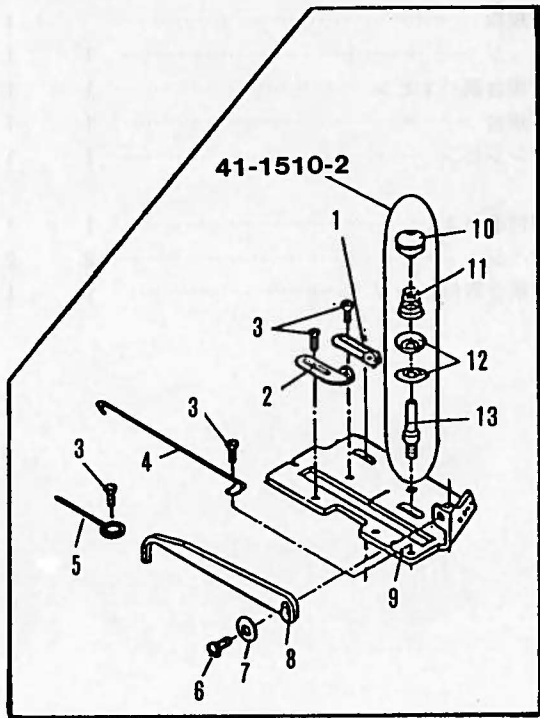

40-3840-0

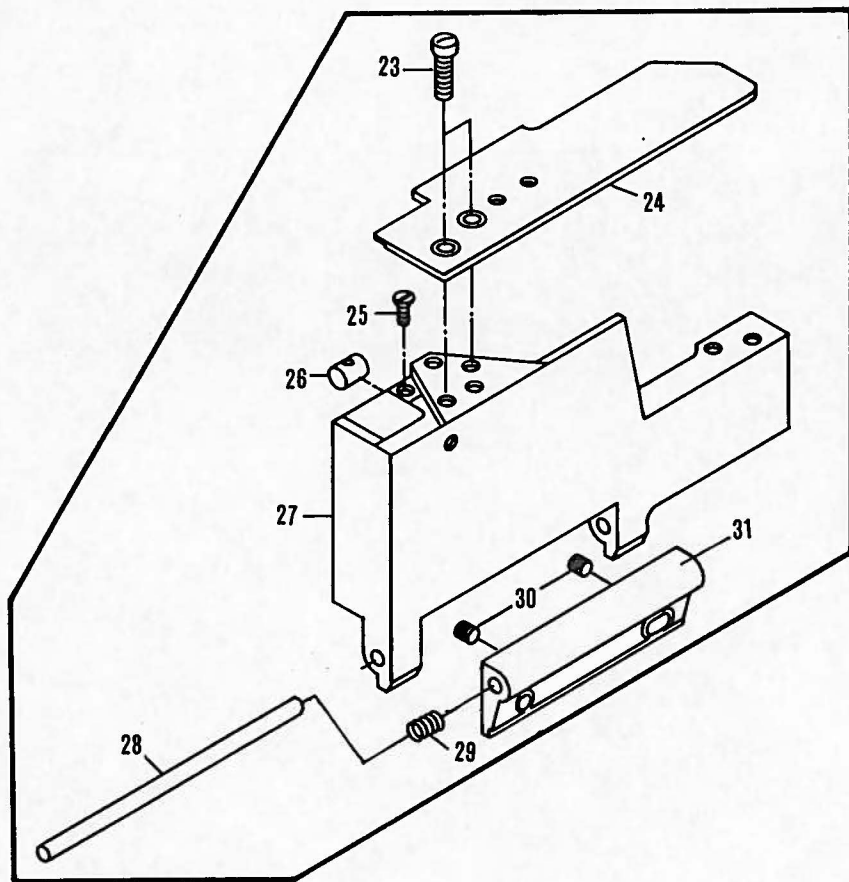
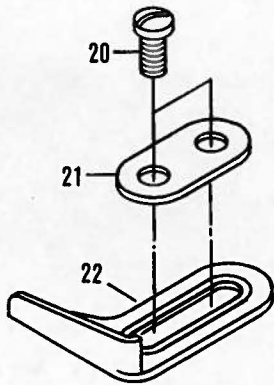
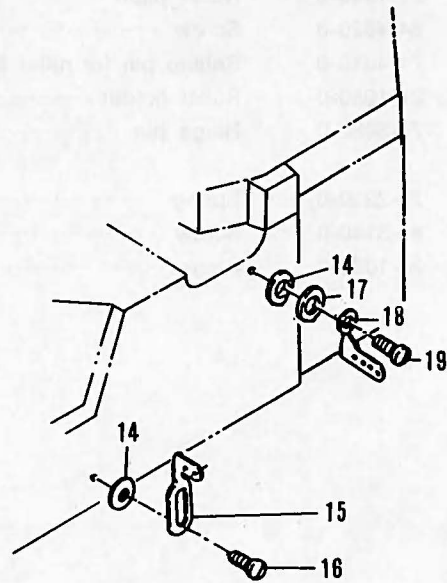

20-0130-5

No.	Part No.	Part Name	品 名	Q, ty
1	47-1320-0	Looper thread eyelet (left) .....	下糸捌き板案内糸道 (左) .....	1
2	47-1310-0	Looper thread guide eyelet (right) .....	下糸捌き板案内糸道 (右) .....	1
3	84-1610-0	Screw .....	ネ ジ .....	4
4	43-3380-0	Looper thread retainer .....	下糸捌き下ピン .....	1
5	43-1050-0	Pin .....	下糸捌きピン .....	1
6	84-3610-0	Screw .....	ネ ジ .....	1
7	75-4680-0	Washer .....	ワッシャ .....	1
8	43-3440-0	Looper thread retainer .....	下糸捌き上 .....	1
9	43-3420-0	Cast-off support bracket .....	下糸捌き板 .....	1
10	41-1540-0	Nut .....	ナット .....	1
11	41-1530-0	Spring .....	バ ネ .....	1
12	41-1520-0	Tension nipper .....	捌き用小チャンボン皿 .....	2
13	41-1510-0	Looper thread guide tension stud .....	下糸チャンボン用調子棒 .....	1
14	23-1870-0	O-ring .....	Oリング .....	2
15	45-1020-0	Looper thread eyelet .....	下糸糸道 .....	1
16	84-3610-0	Screw .....	ネ ジ .....	1
17	75-4550-0	Washer .....	ワッシャ .....	1
18	47-1660-0	Looper thread eyelet .....	下糸糸道 .....	1
19	84-5660-0	Screw .....	ネ ジ .....	1
20	85-1810-0	Screw .....	ネ ジ .....	2
21	26-7120-0	Folder bracket .....	ラッパ取付台 .....	1
22	26-5520-0	Guide .....	ガイド定規 .....	1
23	84-5720-0	Screw .....	ネ ジ .....	2
24	21-1940-0	Ruller plate .....	定規板 .....	1
25	84-4620-0	Screw .....	ネ ジ .....	1
26	71-4010-0	Setting pin for ruller holder spring .....	定規台裏バネピン .....	1
27	21-1080-0	Ruller holder .....	定規台 .....	1
28	71-3080-0	Hinge pin .....	ヒンジピン .....	1
29	79-2330-0	Spring .....	取付巻バネ .....	1
30	84-3140-0	Screw .....	ネ ジ .....	2
31	25-1080-0	Hinge .....	定規台取付ヒンジ .....	1

## 19. Gauge parts (ゲージ関係)

No.	Model	Feed dog holder	Needle holder	Needle plate	Feed dog (front)	Feed dog (rear)	Presser foot	Looper
1	<b>W8002D</b> 1/8	51-1180-0	12-8110-1	14-7240-0	15-7240-0	15-7550-0	17-8240-1	19-8010-0
2	5/32	51-1180-0	12-8120-1	14-7340-0	15-7240-0	15-7550-0	17-8340-1	19-8010-0
3	3/16	51-1180-0	12-8130-1	14-7440-0	15-7230-0	15-7530-0	17-8440-1	19-8010-0
4	7/32	51-1180-0	12-8140-1	14-7540-0	15-7230-0	15-7530-0	17-8540-1	19-8010-0
5	1/4	51-1180-0	12-8150-1	14-7640-0	15-7230-0	15-7530-0	17-8640-1	19-8010-0
6	<b>W8003D</b> 7/32	51-1180-0	12-8010-1	14-8540-0	15-7230-0	15-7530-0	17-8840-1	19-8010-0
7	1/4	51-1180-0	12-8020-1	14-8640-0	15-7230-0	15-7530-0	17-8940-1	19-8010-0
8	<b>V7001D</b>	51-1180-0	12-8010-1	14-7040-0	15-7240-0	15-7540-0	17-7040-1	19-8010-0
9	<b>V7002D</b> 1/8	51-1180-0	12-8110-1	14-7240-0	15-7240-0	15-7550-0	17-7240-1	19-8010-0
10	5/32	51-1180-0	12-8120-1	14-7340-0	15-7240-0	15-7550-0	17-7340-1	19-8010-0
11	3/16	51-1180-0	12-8130-1	14-7440-0	15-7230-0	15-7530-0	17-7440-1	19-8010-0
12	7/32	51-1180-0	12-8140-1	14-7540-0	15-7230-0	15-7530-0	17-7540-1	19-8010-0
13	1/4	51-1180-0	12-8150-1	14-7640-0	15-7230-0	15-7530-0	17-7640-1	19-8010-0
14	<b>V7003D</b> 7/32	51-1180-0	12-8010-1	14-8540-0	15-7230-0	15-7530-0	17-7840-1	19-8010-0
15	1/4	51-1180-0	12-8020-1	14-8640-0	15-7230-0	15-7530-0	17-7940-1	19-8010-0
16	<b>W8002C</b> 3/16	51-1180-0	12-8130-1	14-8030-0	15-7310-0	15-7610-0	17-8470-1	19-8010-0
17	7/32	51-1180-0	12-8140-1	14-8040-0	15-7310-0	15-7610-0	17-8570-1	19-8010-0
18	1/4	51-1180-0	12-8150-1	14-8050-0	15-7310-0	15-7610-0	17-8670-1	19-8010-0
19	<b>W8003C</b> 7/32	51-1180-0	12-8010-1	14-8010-0	15-7310-0	15-7610-0	17-8870-1	19-8010-0
20	1/4	51-1180-0	12-8020-1	14-8020-0	15-7310-0	15-7610-0	17-8970-1	19-8010-0
21	<b>V7001F</b>	51-1170-0	12-8010-1	14-7030-0	15-7260-0	15-7570-0	17-7030-1	19-8010-0
22	<b>V7002F, W8002F, DMM2202F</b> 1/8	51-1170-0	12-8110-1	14-7260-0	15-7290-0	15-7580-0	17-8260-1	19-8010-0
23	5/32	51-1170-0	12-8120-1	14-7360-0	15-7290-0	15-7580-0	17-8360-1	19-8010-0
24	3/16	51-1170-0	12-8130-1	14-7460-0	15-7270-0	15-7560-0	17-8460-1	19-8010-0
25	7/32	51-1170-0	12-8140-1	14-7560-0	15-7270-0	15-7560-0	17-8560-1	19-8010-0
26	1/4	51-1170-0	12-8150-1	14-7660-0	15-7270-0	15-7560-0	17-8660-1	19-8010-0
27	<b>V7003F, W8003F, DMM2203F</b> 7/32	51-1170-0	12-8010-1	14-8560-0	15-7270-0	15-7560-0	17-8860-1	19-8010-0
28	1/4	51-1170-0	12-8020-1	14-8660-0	15-7270-0	15-7560-0	17-8960-1	19-8010-0
29	<b>V7002DE</b> 1/8	51-1180-0	12-8110-1	14-7250-0	15-7240-0	15-7550-0	17-7250-1	19-8010-0

No.	Model	Feed dog holder	Needle holder	Needle plate	Feed dog (front)	Feed dog (rear)	Presser foot	Looper
30	5/32	51-1180-0	12-8120-1	14-7350-0	15-7240-0	15-7550-0	17-7350-1	19-8010-0
31	3/16	51-1180-0	12-8130-1	14-7450-0	15-7230-0	15-7530-0	17-7450-1	19-8010-0
32	7/32	51-1180-0	12-8140-1	14-7550-0	15-7230-0	15-7530-0	17-7550-1	19-8010-0
33	1/4	51-1180-0	12-8150-1	14-7650-0	15-7230-0	15-7530-0	17-7650-1	19-8010-0
34	V7003DE 7/32	51-1180-0	12-8010-1	14-8550-0	15-7230-0	15-7530-0	17-7850-1	19-8010-0
35	1/4	51-1180-0	12-8020-1	14-8650-0	15-7230-0	15-7530-0	17-7950-1	19-8010-0
36	W8002DE 1/8	51-1180-0	12-8110-1	14-7250-0	15-7240-0	15-7550-0	17-8250-1	19-8010-0
37	5/32	51-1180-0	12-8120-1	14-7350-0	15-7240-0	15-7550-0	17-8350-1	19-8010-0
38	3/16	51-1180-0	12-8130-1	14-7450-0	15-7230-0	15-7530-0	17-8450-1	19-8010-0
39	7/32	51-1180-0	12-8140-1	14-7550-0	15-7230-0	15-7530-0	17-8550-1	19-8010-0
40	1/4	51-1180-0	12-8150-1	14-7650-0	15-7230-0	15-7530-0	17-8650-1	19-8010-0
41	W8003DE 7/32	51-1180-0	12-8010-1	14-8550-0	15-7230-0	15-7530-0	17-8850-1	19-8010-0
42	1/4	51-1180-0	12-8020-1	14-8650-0	15-7230-0	15-7530-0	17-8950-1	19-8010-0
43	W8004D 6M/M	51-1180-0	12-8210-1	14-8210-0	15-7230-0	15-7530-0	17-8210-1	19-7130-0
44	W8042	51-1180-0	12-8420-1	14-8420-0	15-8410-0	15-8400-0	17-8420-1	19-8100-0 19-8110-0
45	W8042-1		12-8410-1	14-8410-0	15-8400-0		17-8410-1	19-8120-0 19-8130-0 19-8140-0
46	V7002ML 1/8	51-1180-0	12-8110-1	14-7230-0	15-7240-0	15-7550-0	17-7230-1	19-7140-0
47	V7002D/UTC 1/8	51-7720-0	12-8110-1	14-7240-0	15-7320-0	15-7420-0	17-7240-1	19-8010-0
48	5/32	51-7720-0	12-8120-1	14-7340-0	15-7320-0	15-7420-0	17-7340-1	19-8010-0
49	3/16	51-7720-0	12-8130-1	14-7440-0	15-7330-0	15-7430-0	17-7440-1	19-8010-0
50	7/32	51-7720-0	12-8140-1	14-7540-0	15-7330-0	15-7430-0	17-7540-1	19-8010-0
51	1/4	51-7720-0	12-8150-1	14-7640-0	15-7330-0	15-7430-0	17-7640-1	19-8010-0
52	V7003D/UTC 7/32	51-7720-0	12-8010-1	14-8540-0	15-7330-0	15-7430-0	17-7840-1	19-8010-0
53	1/4	51-7720-0	12-8020-1	14-8640-0	15-7330-0	15-7430-0	17-7940-1	19-8010-0
54	L5001M L5001M/UTC		12-8010-1	14-5010-0	15-5010-0		17-5010-1	19-5040-0
55	L5001MF		12-8010 <sub>1</sub>	14-5060-0	15-5060-0		17-5060-1	19-5040-0
56	L5002TMF Oゲージ		12-5980-1	14-5980-0	15-5980-0	17-5980-1		19-5260-0 19-5980-0
57	W8003-1S 7/32-5/32	51-1300-0	12-8920-1	14-7830-0	15-7830-0	15-7270-0	17-8910-1	19-8010-0 19-3260-0
58	V7002-1S 3,5-4	51-1300-0	12-7920-1	14-7920-0	15-7920-0	15-7290-0	17-7920-1	19-8010-0 19-3260-0

V7000D(1/8"-1/4")

W8000D(1/8"-1/4")

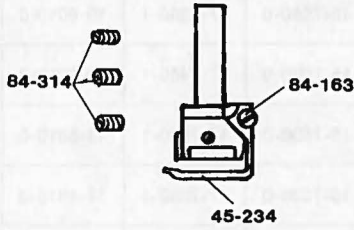

	mm	Part No.	
1/8"	3.17	12-8110-1	2 Needles
3/32"	3.97	12-8120-1	
3/16"	4.76	12-8130-1	
7/32"	5.56	12-8140-1	
1/4"	6.35	12-8150-1	3 Needles
7/32"	5.56	12-8010-1	
1/4"	6.35	12-8020-1	

Needle holder (2,3 Needles)



	mm	Part No.	
1/8"	3.17	14-7240	2 Needles
3/32"	3.97	14-7340	
3/16"	4.76	14-7440	
7/32"	5.56	14-7540	
1/4"	6.35	14-7640	3 Needles
7/32"	5.56	14-8540	
1/4"	6.35	14-8640	



Needle plate(2 Needles)

Needle plate(3 Needles)

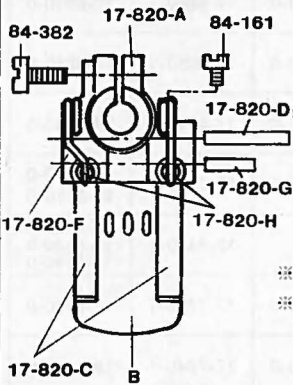

	mm	Part No.	
1/8"	3.17	17-7240-1	3 Needles
3/32"	3.97	17-7340-1	
3/16"	4.76	17-7440-1	
7/32"	5.56	17-7540-1	
1/4"	6.35	17-7640-1	3 Needles
7/32"	5.56	17-7840-1	
1/4"	6.35	17-7940-1	

Presser foot (2,3 Needles)

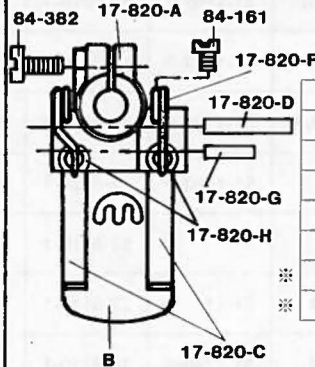

	mm	Part No.	
1/8"	3.17	17-8240-1	3 Needles
3/32"	3.97	17-8340-1	
3/16"	4.76	17-8440-1	
7/32"	5.56	17-8540-1	
1/4"	6.35	17-8640-1	3 Needles
7/32"	5.56	17-8840-1	
1/4"	6.35	17-8940-1	

Presser foot (2,3 Needles)

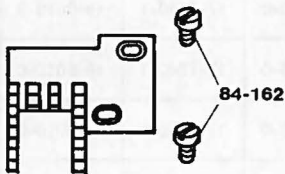

	mm	Part No.	
1/8"	3.17	15-7550	3 Needles
3/32"	3.97	15-7550	
3/16"	4.76	15-7530	
7/32"	5.56	15-7530	
1/4"	6.35	15-7530	3 Needles
7/32"	5.56	15-7530	
1/4"	6.35	15-7530	

Feed dog (Rear)

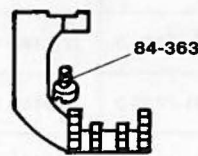

	mm	Part No.	
1/8"	3.17	15-7240	3 Needles
3/32"	3.97	15-7240	
3/16"	4.76	15-7230	
7/32"	5.56	15-7230	
1/4"	6.35	15-7230	3 Needles
7/32"	5.56	15-7230	
1/4"	6.35	15-7230	

Feed dog (front)

51-1180-0





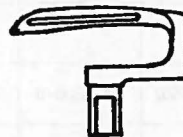

Rear feed dog holder

19-8010-0

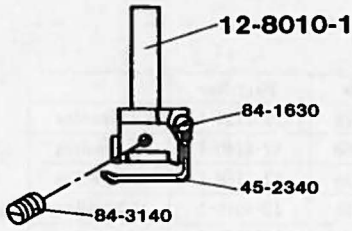
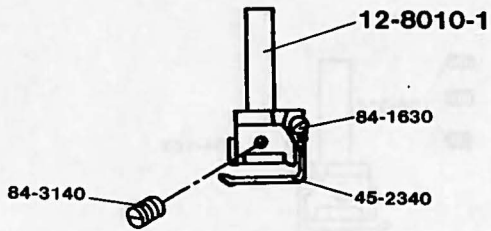
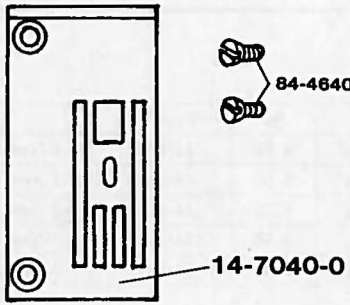
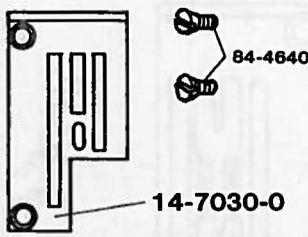
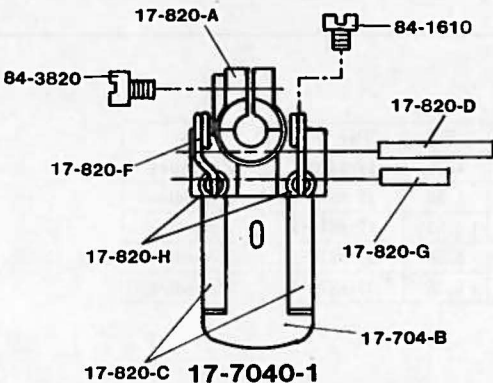
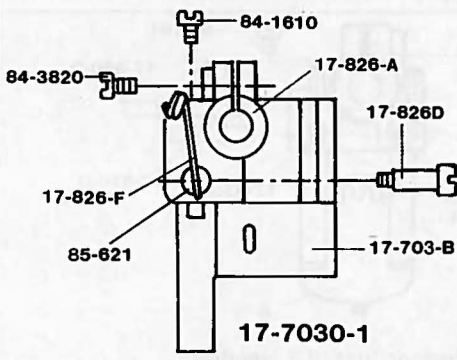
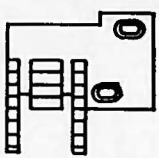
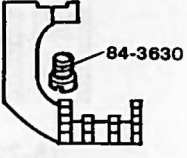
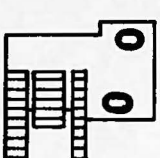
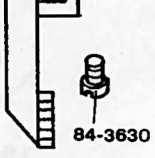

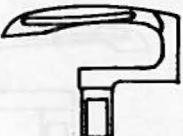
Looper

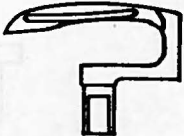
V7001D	V7001F
 <p>12-8010-1 84-1630 45-2340 84-3140</p> <p>Needle holder</p>	 <p>12-8010-1 84-1630 45-2340 84-3140</p> <p>Needle holder</p>
 <p>84-4640 14-7040-0</p> <p>Needle plate</p>	 <p>84-4640 14-7030-0</p> <p>Needle plate</p>
 <p>17-820-A 84-3820 17-820-F 17-820-H 17-820-C 17-7040-1 17-704-B 17-820-D 84-1610 17-820-G</p> <p>Presser foot</p>	 <p>84-3820 17-826-A 17-826-F 85-621 84-1610 17-826-D 17-703-B 17-7030-1</p> <p>Presser foot</p>
 <p>15-7540-0</p> <p>Feed dog (Rear)</p>  <p>84-1620 84-3630</p> <p>15-7240-0</p> <p>Feed dog (front)</p>	 <p>15-7570-0</p> <p>Feed dog (Rear)</p>  <p>84-1620 84-3630</p> <p>15-7260-0</p> <p>Feed dog (front)</p>
 <p>51-1180-0</p> <p>Rear feed dog holder</p>  <p>19-8010-0</p> <p>Looper</p>	 <p>51-1170-0</p> <p>Rear feed dog holder</p>  <p>19-8010-0</p> <p>Looper</p>



**W8000C(3/16"-1/4")**

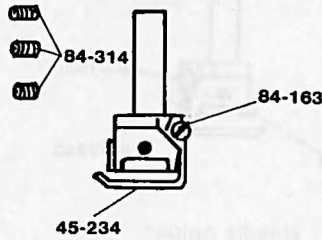

**Needle holder (2,3 Needles)**

	$\frac{m}{m}$	Part No.	
$\frac{3}{16}$ "	4.76	12-8130-1	2 Needles
$\frac{7}{32}$ "	5.56	12-8140-1	2 Needles
$\frac{1}{4}$ "	6.35	12-8150-1	2 Needles
$\frac{7}{32}$ "	5.56	12-8010-1	3 Needles
$\frac{1}{4}$ "	6.35	12-8020-1	3 Needles

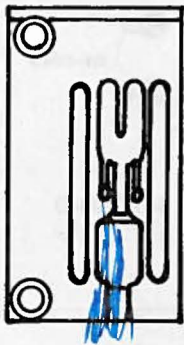

**Needle plate (2,3 Needles)**

	$\frac{m}{m}$	Part No.	
$\frac{3}{16}$ "	4.76	14-8030	2 Needles
$\frac{7}{32}$ "	5.56	14-8040	2 Needles
$\frac{1}{4}$ "	6.35	14-8050	2 Needles
$\frac{7}{32}$ "	5.56	14-8010	3 Needles
$\frac{1}{4}$ "	6.35	14-8020	3 Needles

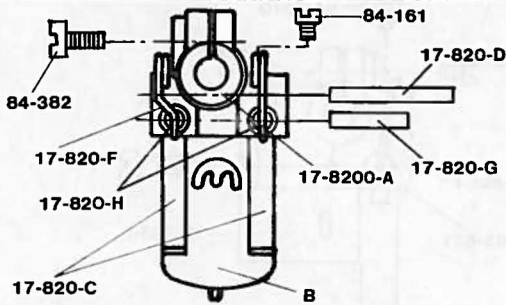

**Presser foot (2,3 Needles)**

	$\frac{m}{m}$	Part No.	
$\frac{3}{16}$ "	4.76	17-8470-1	2 Needles
$\frac{7}{32}$ "	5.56	17-8570-1	2 Needles
$\frac{1}{4}$ "	6.35	17-8670-1	2 Needles
$\frac{7}{32}$ "	5.56	17-8870-1	3 Needles
$\frac{1}{4}$ "	6.35	17-8970-1	3 Needles

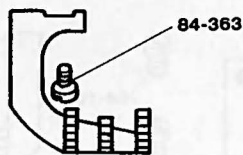

**15-7610-0**

**Feed dog (front)**

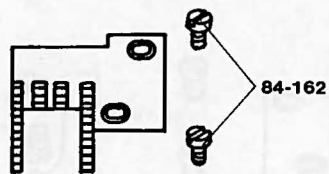

**15-7310-0**

**Feed dog (Rear)**

**51-1180-0**



**Feed dog holder**

**19-8010-0**

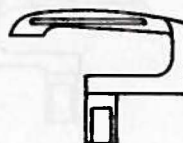

**Looper**

V7002F(1/8"-1/4"), W8002F(1/8"-1/4"), DMM2202F

V7003F(7/32"-1/4"), W8003F(7/32"-1/4), DMM2203F

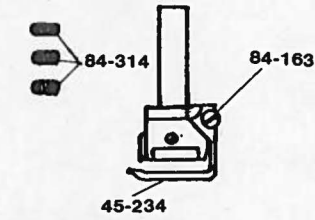

Needle holder (2,3 Needles)

	mm	Part No.	
1/8"	3.17	12-8110-1	2 Needles
3/16"	3.97	12-8120-1	
1/4"	4.76	12-8130-1	
5/16"	5.56	12-8140-1	
3/8"	5.56	12-8010-1	3 Needles
1/2"	6.35	12-8020-1	

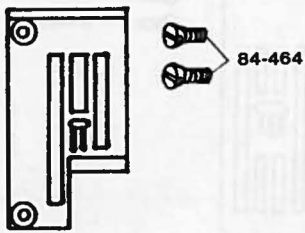

Needle plate (2 Needles)

	mm	Part No.	
1/8"	3.17	14-7260	2 Needles
3/16"	3.97	14-7360	
1/4"	4.76	14-7460	
5/16"	5.56	14-7560	
3/8"	5.56	14-8560	3 Needles
1/2"	6.35	14-8660	

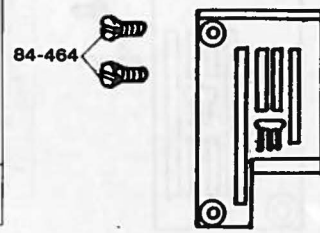

Needle plate (3 Needles)

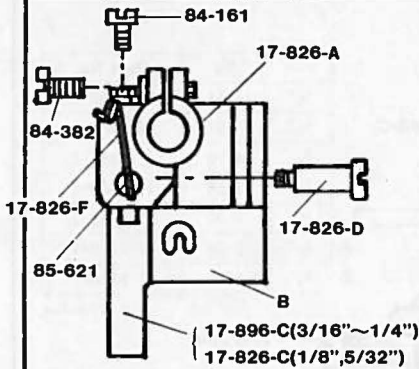

Presser foot (2 Needles)

	mm	Part No.	
1/8"	3.17	17-8260-1	2 Needles
3/16"	3.97	17-8360-1	
1/4"	4.76	17-8460-1	
5/16"	5.56	17-8560-1	
3/8"	5.56	17-8860-1	3 Needles
1/2"	6.35	17-8960-1	

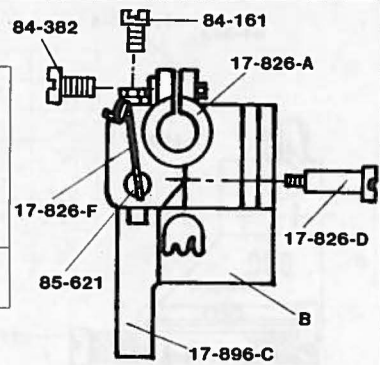

Presser foot (3 Needles)

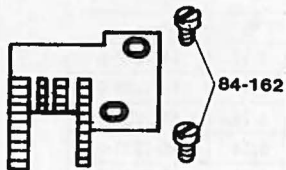

Feed dog (Rear)

	mm	Part No.
1/8"	3.17	15-7580-0
3/16"	3.97	15-7580-0
1/4"	4.76	15-7560-0
5/16"	5.56	15-7560-0
3/8"	6.35	15-7560-0
※ 3/8"	5.56	15-7560-0
※ 1/2"	6.35	15-7560-0

※ 3 Needles

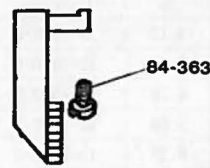

Feed dog (Front)

	mm	Part No.
1/8"	3.17	15-7290-0
3/16"	3.97	15-7290-0
1/4"	4.76	15-7270-0
5/16"	5.56	15-7270-0
3/8"	6.35	15-7270-0
※ 3/8"	5.56	15-7270-0
※ 1/2"	6.35	15-7270-0

※ 3 Needles

51-1170-0



Rear feed dog holder

19-8010-0



Looper

V7000DE

W8000DE

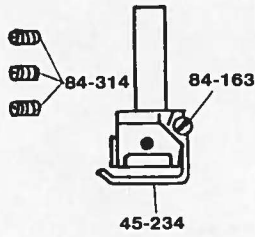

	mm	Part No.	
1/8"	3.17	12-8110-1	2 Needles
3/16"	3.97	12-8120-1	
1/4"	4.76	12-8130-1	
5/16"	5.56	12-8140-1	
3/8"	5.56	12-8010-1	3 Needles
1/2"	6.35	12-8020-1	

Needle holder (2,3 Needles)

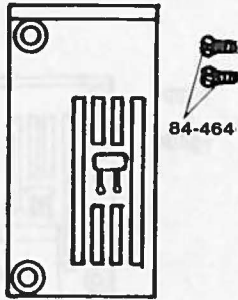

	mm	Part No.	
1/8"	3.17	14-7250	2 Needles
3/16"	3.97	14-7350	
1/4"	4.76	14-7450	
5/16"	5.56	14-7550	
3/8"	5.56	14-8550	3 Needles
1/2"	6.35	14-8650	

Needle plate (2 Needles)

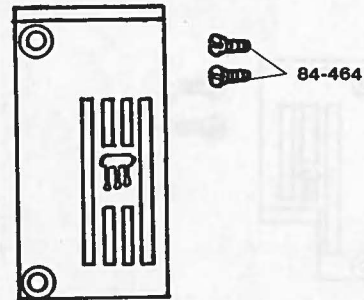

Needle plate (3 Needles)

	mm	Part No.	
1/8"	3.17	17-7250-1	2 Needles
3/16"	3.97	17-7350-1	
1/4"	4.76	17-7450-1	
5/16"	5.56	17-7550-1	
3/8"	5.56	17-7850-1	3 Needles
1/2"	6.35	17-7950-1	

Presser foot (2,3 Needles)

	mm	Part No.	
1/8"	3.17	17-8250-1	2 Needles
3/16"	3.97	17-8350-1	
1/4"	4.76	17-8450-1	
5/16"	5.56	17-8550-1	
3/8"	5.56	17-8850-1	3 Needles
1/2"	6.35	17-8950-1	

Presser foot (2,3 Needles)

	mm	Part No.	
1/8"	3.17	15-7550-0	2 Needles
3/16"	3.97	15-7550-0	
1/4"	4.76	15-7530-0	
5/16"	5.56	15-7530-0	
3/8"	5.56	15-7530-0	3 Needles
1/2"	6.35	15-7530-0	

Feed dog (Rear)

	mm	Part No.	
1/8"	3.17	15-7240-0	2 Needles
3/16"	3.97	15-7240-0	
1/4"	4.76	15-7230-0	
5/16"	5.56	15-7230-0	
3/8"	5.56	15-7230-0	3 Needles
1/2"	6.35	15-7230-0	

Feed dog (front)

51-1180-0







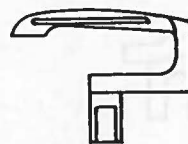

Rear feed dog holder

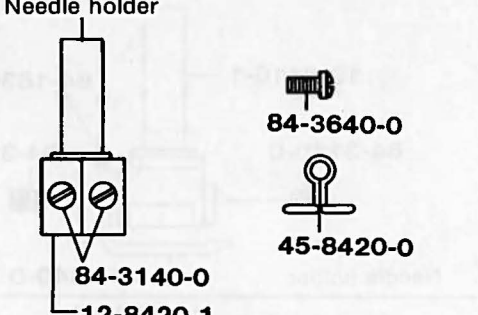
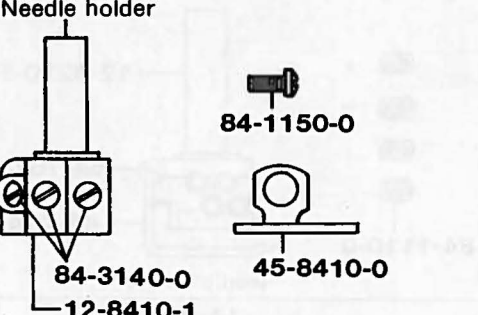
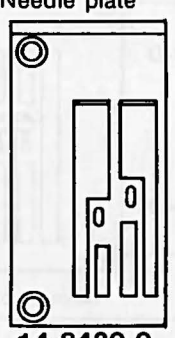
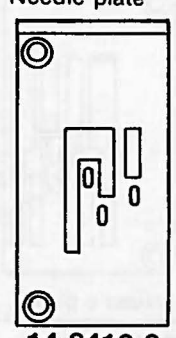
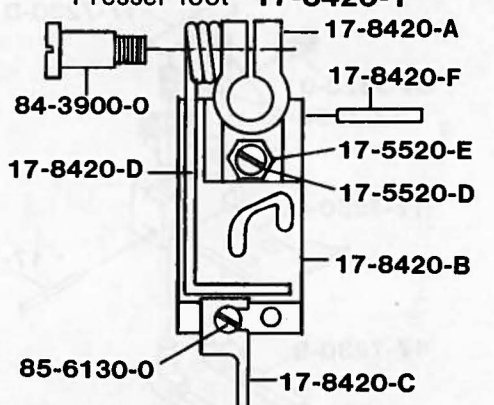
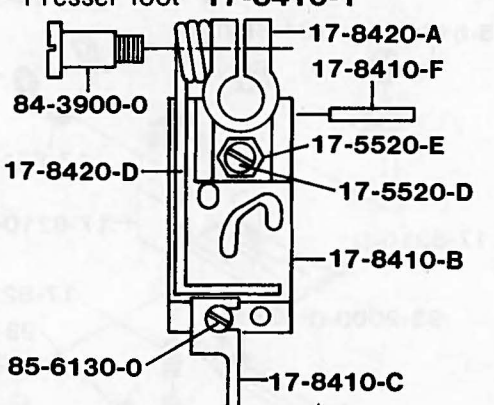
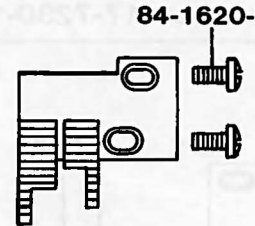
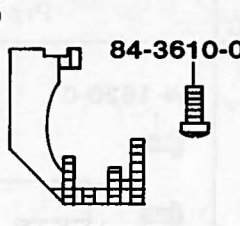
19-8010-0

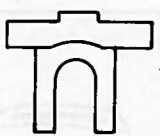
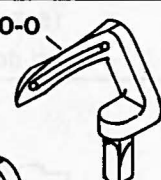

Looper

W8042	W8042-1
<p>Needle holder</p>  <p>84-3140-0 12-8420-1</p> <p>84-3640-0</p> <p>45-8420-0</p>	<p>Needle holder</p>  <p>84-3140-0 12-8410-1</p> <p>84-1150-0</p> <p>45-8410-0</p>
<p>Needle plate</p>  <p>14-8420-0</p> <p>84-4640-0</p>	<p>Needle plate</p>  <p>14-8410-0</p> <p>84-4640-0</p>
<p>Presser foot <b>17-8420-1</b></p>  <p>84-3900-0</p> <p>17-8420-A</p> <p>17-8420-F</p> <p>17-8420-D</p> <p>17-5520-E</p> <p>17-5520-D</p> <p>17-8420-B</p> <p>85-6130-0</p> <p>17-8420-C</p>	<p>Presser foot <b>17-8410-1</b></p>  <p>84-3900-0</p> <p>17-8420-A</p> <p>17-8410-F</p> <p>17-8420-D</p> <p>17-5520-E</p> <p>17-5520-D</p> <p>17-8410-B</p> <p>85-6130-0</p> <p>17-8410-C</p>
<p>84-1620-0</p>  <p>15-8420-0</p> <p>Feed dog (Rear)</p> <p>84-3610-0</p>  <p>15-8410-0</p> <p>Feed dog (Front)</p>	 <p>15-8400-0</p> <p>Feed dog</p> <p>84-3630-0</p>
<p>51-1180-0</p>  <p>Rear feed dog holder</p> <p>19-8100-0</p>  <p>19-8110-0</p>  <p>Looper</p>	<p>19-8130-0</p>  <p>19-8120-0</p>  <p>19-8140-0</p>  <p>Looper</p>

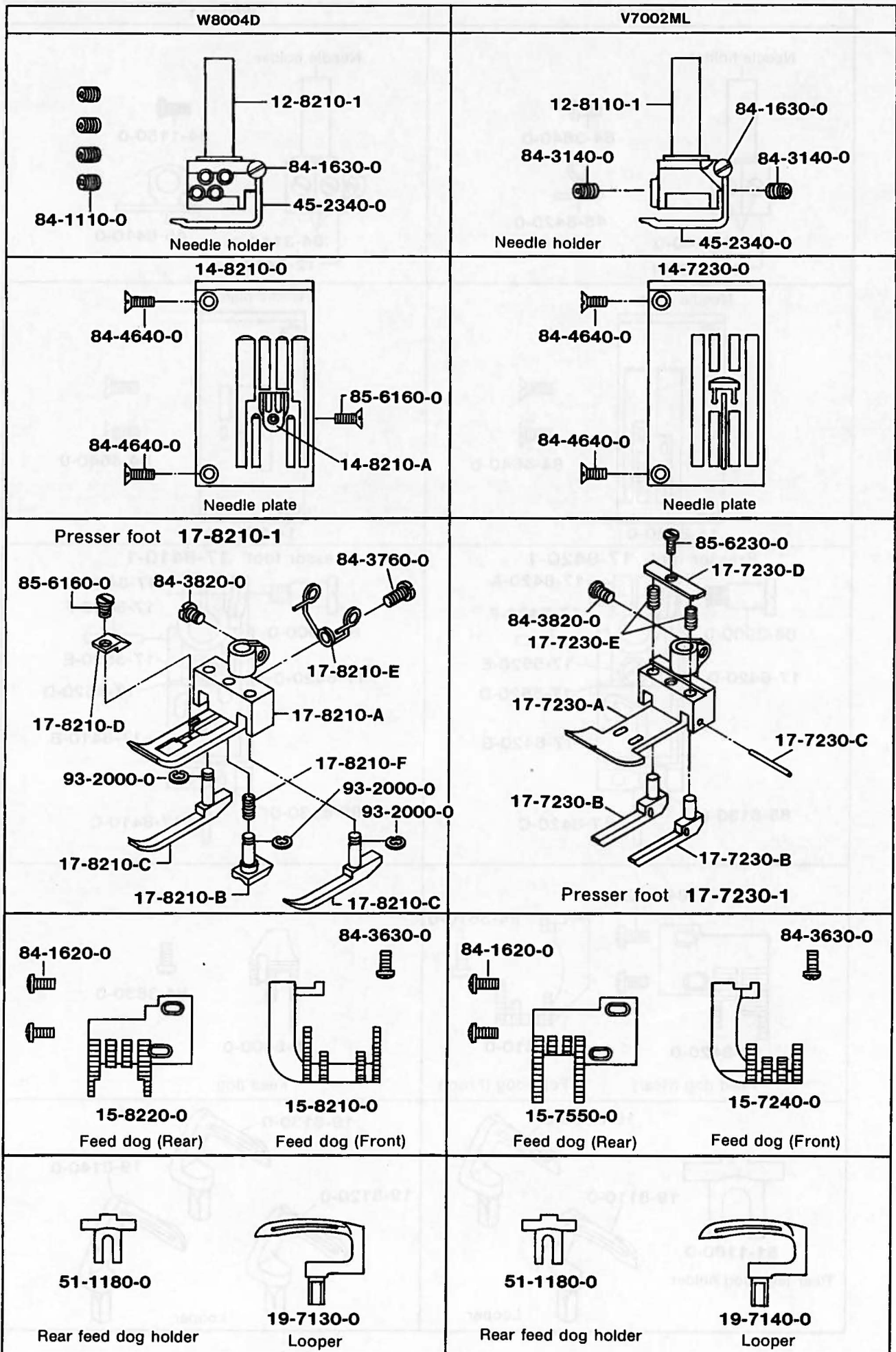

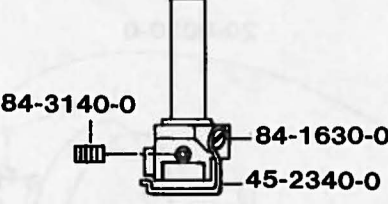
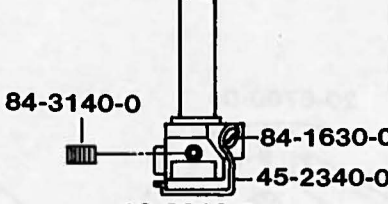
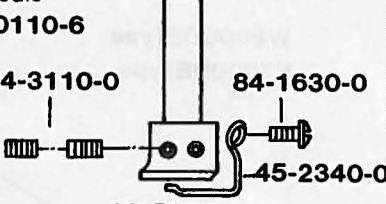
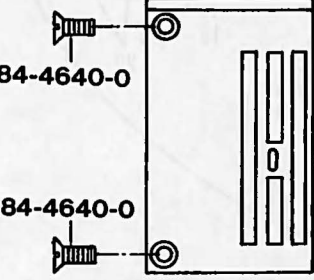
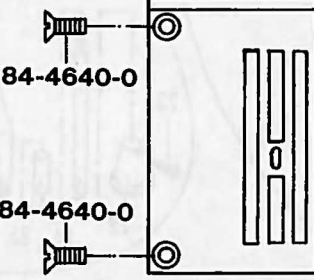
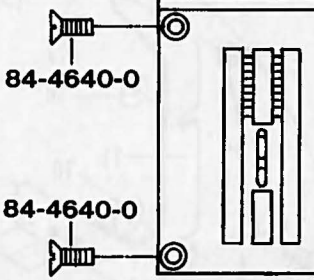
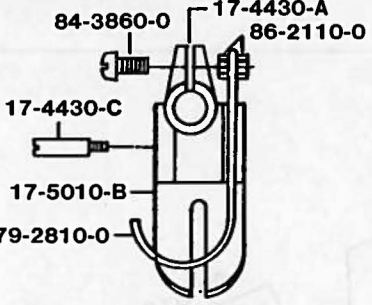
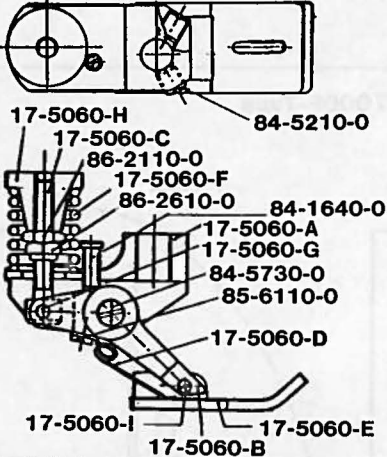
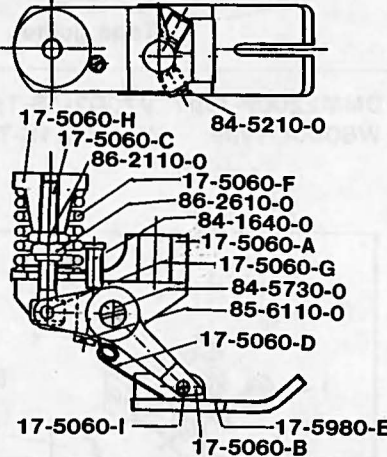
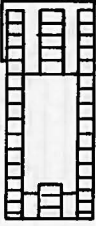
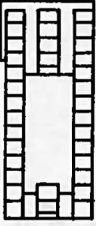
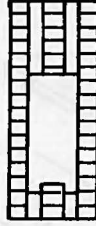
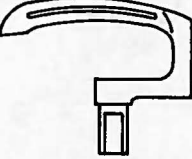
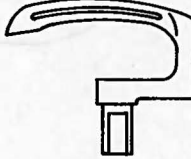
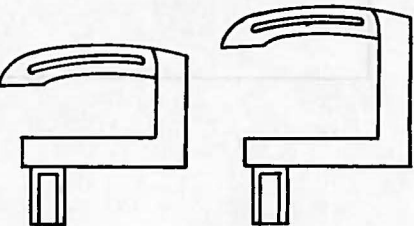
L5001M	L5001MF	L5002TMF O-gauge
 <p>84-3140-0 84-1630-0 45-2340-0 <b>12-8010-1</b> Needle holder</p>	 <p>84-3140-0 84-1630-0 45-2340-0 <b>12-8010-1</b> Needle holder</p>	<p>Needle 13-0110-6</p>  <p>84-3110-0 84-1630-0 45-2340-0 <b>12-5980-1</b> Needle holder</p>
 <p>84-4640-0 84-4640-0 <b>14-5010-0</b> Needle plate</p>	 <p>84-4640-0 84-4640-0 <b>14-5060-0</b> Needle plate</p>	 <p>84-4640-0 84-4640-0 <b>14-5980-0</b> Needle plate</p>
<p>Presser foot <b>17-5010-1</b></p>  <p>84-3860-0 17-4430-A 86-2110-0 17-4430-C 17-5010-B 79-2810-0</p>	<p>Presser foot <b>17-5060-1</b></p>  <p>17-5060-H 17-5060-C 86-2110-0 17-5060-F 86-2610-0 84-1640-0 17-5060-A 17-5060-G 84-5730-0 85-6110-0 17-5060-D 17-5060-I 17-5060-E 17-5060-B</p>	<p>Presser foot <b>17-5980-1</b></p>  <p>17-5060-H 17-5060-C 86-2110-0 17-5060-F 86-2610-0 84-1640-0 17-5060-A 17-5060-G 84-5730-0 85-6110-0 17-5060-D 17-5060-I 17-5980-E 17-5060-B</p>
<p>Feed dog <b>15-5010-0</b></p> 	<p>Feed dog <b>15-5060-0</b></p> 	<p>Feed dog <b>15-5980-0</b></p> 
 <p><b>19-5040-0</b> Looper</p>	 <p><b>19-5040-0</b> Looper</p>	 <p><b>19-5260-0</b>      <b>19-5980-0</b> Looper</p>

## 20. Attachments (アタッチメント)

W8000DEType  
V7000DEType

20-6700-0

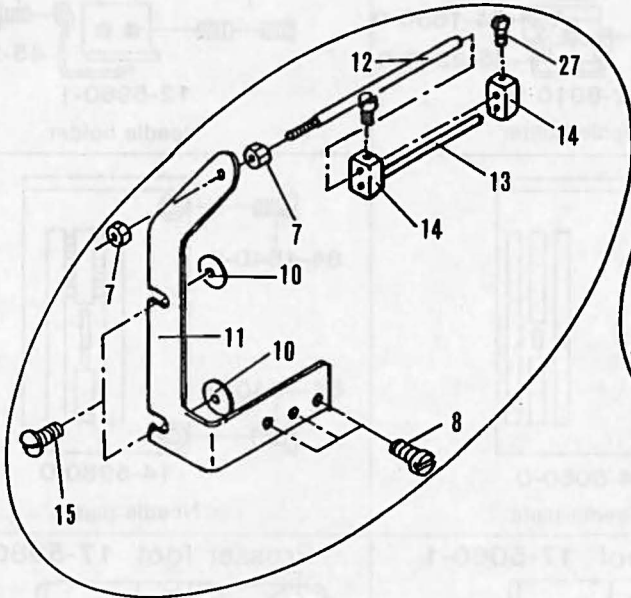

Tape guide

20-6020-0

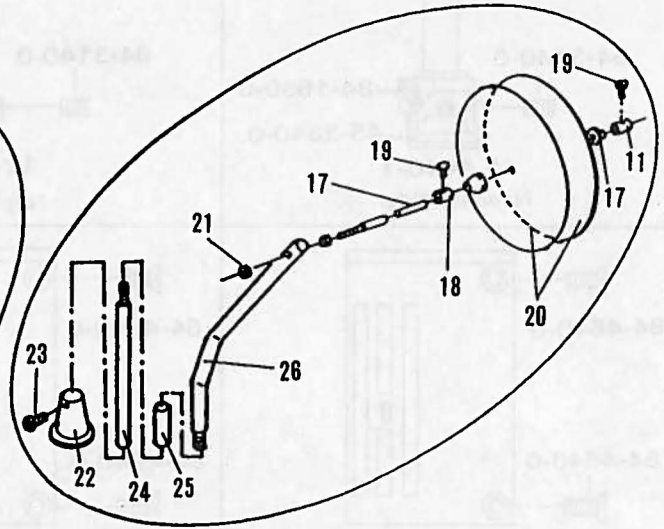

ES-2

DMM2200F-Type V7002-1S-Type V7000F-Type  
W8000F-Type W8003-1S-Type

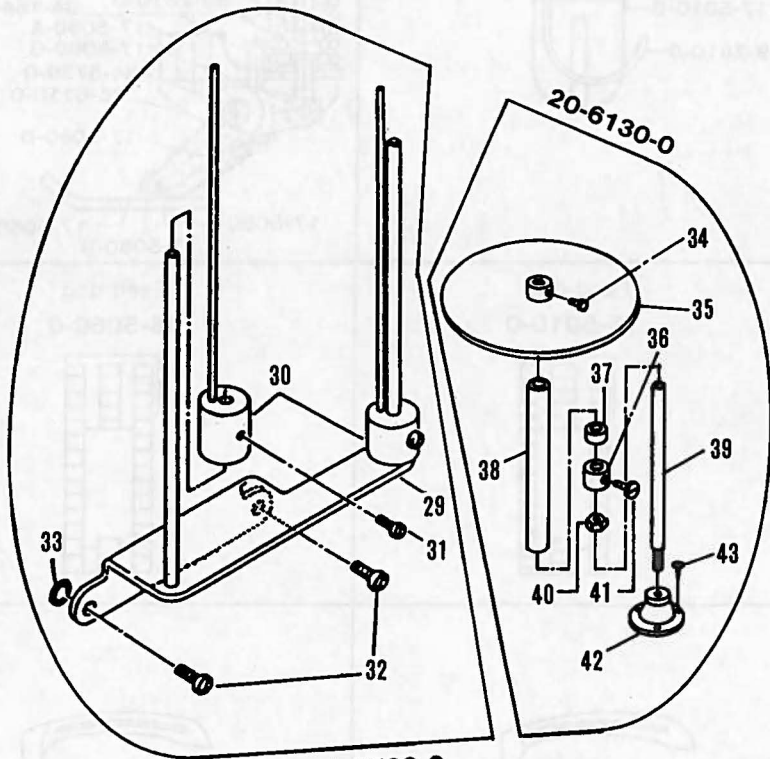
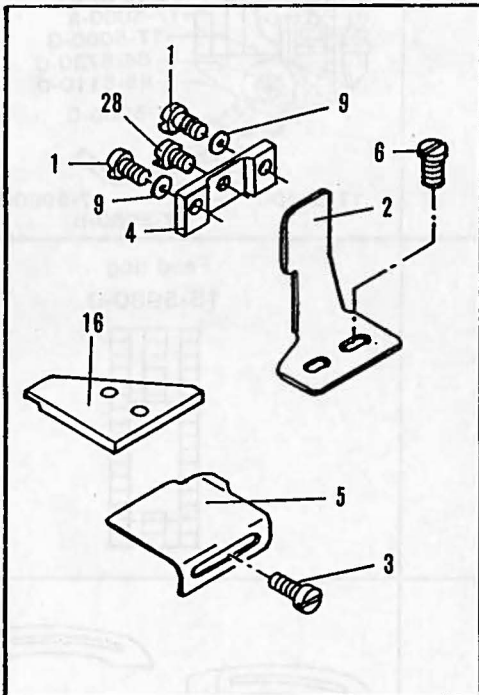

20-6700-0

20-6130-0

No.	Part No.	Part Name	品名	F	D.DE
1	84-5720-0	Screw	ネジ	5	
2	26-7250-0	Folder base	ラッパ取付台	1	
3	84-1620-0	Screw	ネジ	1	
4	26-7240-0	Folder base For F	ラッパ抱き	1	
5	26-7610-0	Plate	定規(前)	1	
6	85-1820-0	Screw	ネジ	2	
7	86-4110-0	Nut	ナット		2
8	84-3630-0	Screw	ネジ		3
9	75-4550-0	Washer	ワッシャ	2	
10	75-4560-0	Washer	ワッシャ		2
11	26-7060-0	Rubber puller guide plate	ゴムプーラー案内板		1
12	26-7510-0	Rubber puller guide bar	ゴムプーラー取付棒		1
13	26-7520-0	Rubber puller guide bar	ゴムプーラー案内棒		1
14	26-7530-0	Rubber puller fittings	ゴムプーラー取付金具		2
15	84-3700-0	Screw	ネジ		2
16	21-1910-0	Rubber plate F	定規板	1	
17	26-8660-0	Tape reel post	テープ支柱C		1
18	26-8690-0	Stop collar	円板受け止めカラーB		2
19	87-1560-0	Hex bolt	メートルネジ		2
20	26-8670-0	Tape reel disk	φ226円板テープガイド		2
21	88-1760-0	Nut	ナット		2
22	26-8760-0	Base	テープ立元台B		1
23	87-1610-0	Hex bolt	メートルネジ		2
24	26-8770-0	Post A	支柱パイプA		2
25	26-8790-0	Connecting pipe	支柱パイプ継手		1
26	26-8780-0	Post B	支柱パイプB		1
27	84-1120-0	Screw	ネジ		2
28	84-5710-0	Screw	ネジ		1
29	26-7020-0	Tape guide bracket	テープガイドブラケット	1	
30	26-7030-0	Tape guide adjuster	テープガイドアジャスター	2	
31	84-5710-0	Screw	ネジ	2	
32	84-5660-0	Screw	ネジ	2	
33	23-1870-0	O-ring	O-リング	2	
34	87-1500-0	Screw	ネジ	1	
35	26-8580-0	φ200 tape reel disc	φ200円板テープガイド	1	
36	26-8600-0	Stop collar	円板受けカラー	1	
37	26-8610-0	Cushion	円板クッションマット	1	
38	26-8590-0	Guide pipe	ガイドパイプ	1	
39	26-8570-0	Post B	テープ支柱B	1	
40	88-1560-0	Nut	ナット	1	
41	87-1490-0	Screw	ネジ	1	
42	26-8560-0	Base	テープ立台B	1	
43	87-9010-0	Wood screw	メートルネジ	3	



# 21. Thread stand (糸立て)

L5002, V7003

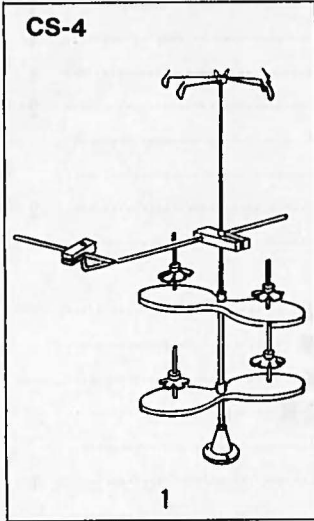

V7002

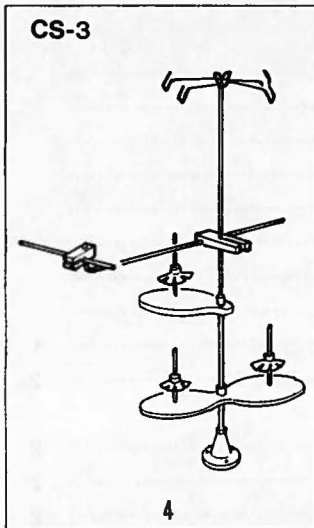

L5001, V7001

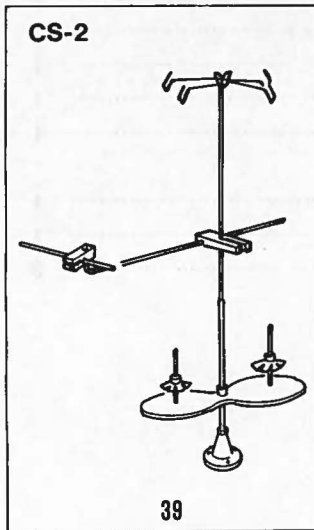

V7002-1S, W8042, W8002

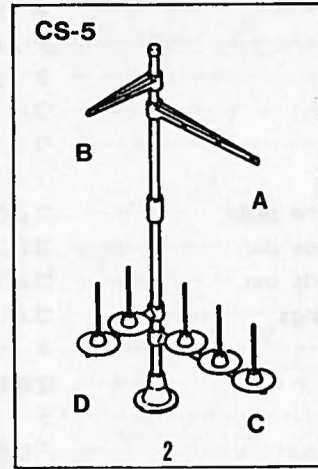

W8003-1S, W8042-1, W8003

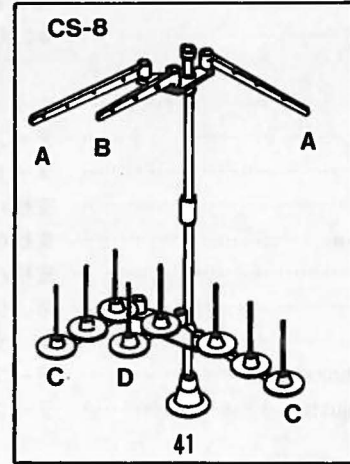
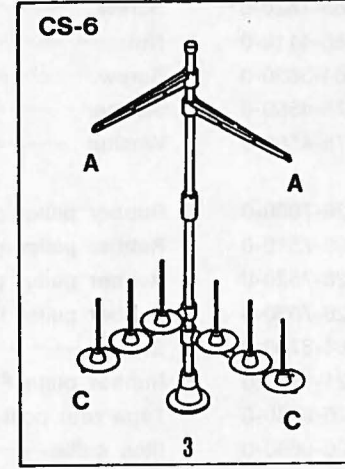

W8004D  
DMM

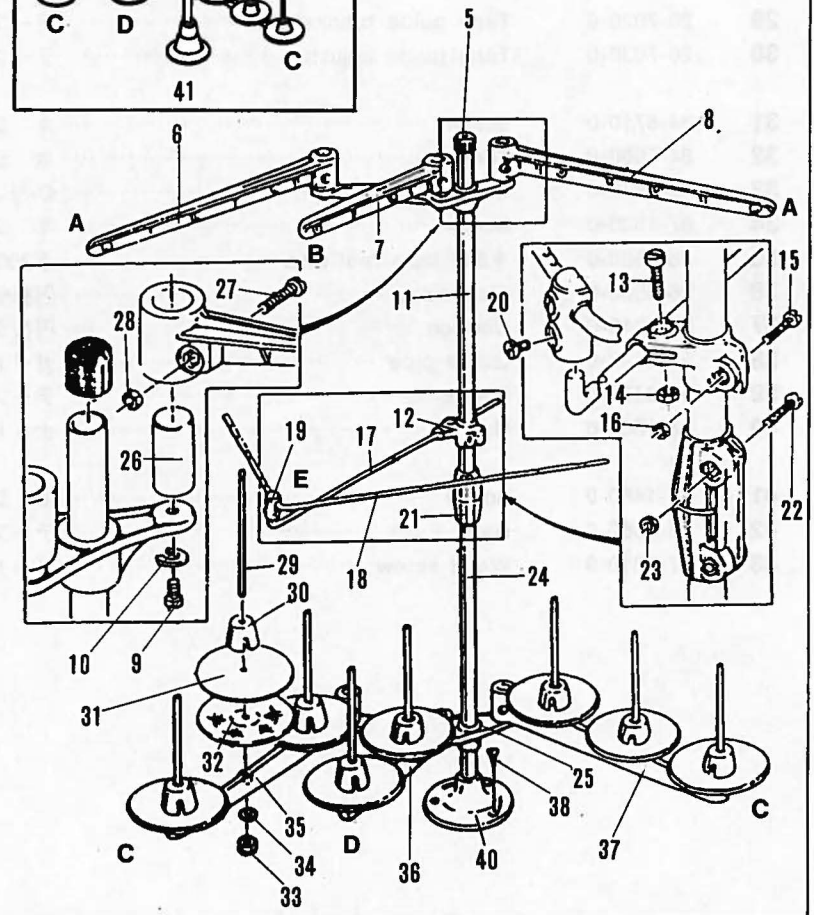

No.	Part No.	Part Name	品名	Q, ty
1	42-0040-0	Thread stand (4)CS-4	4本糸立て	1set
2	42-0050-0	Thread stand (5)CS-5	5本糸立て	1set
3	42-0060-0	Thread stand (6) CS-6	6本糸立て	1set
4	42-0030-0	Thread stand (3) CS-3	3本糸立て	1set
5	42-1200-0	Cap	キャップ	1
6	42-1160-0	Thread guide bracket (3)	糸立て台ブラケット (3)	
7		Thread guide bracket (2)	糸立て台ブラケット (2)	
8		Thread guide bracket (3)	糸立て台ブラケット (3)	
9		Screw	ネジ	6
10		Washer	ワッシャ	6
11	42-1130-0	Bar (upper)	糸立て支柱	1
12		Shank	シャンク	1
13		Screw	ネジ	1
14		Nut	ナット	1
15		Screw	ネジ	1
16		Nut	ナット	1
17		Thread eyelet guide arm bar	糸ガイド棒	1
18		Thread eyelet guide	糸道	1
19		Joint	継手	1
20		Screw	ネジ	2
21		Joint	継手	1
22		Screw	ネジ	2
23		Nut	ナット	2
24	42-1120-0	Bar (low)	糸立て支柱	1
25		Base	糸立て土台	2
26		Mounting bracket	取付ブラケット	6
27		Screw	ネジ	
28		Nut	ナット	
29		Spool pin	糸立てピン	
30		Spool pin retaining fin	糸立て固定具	
31	42-1190-0	Spool mat	クッション	
32	42-1230-0	Spool tray	糸受け皿	
33		Nut	ナット	
34		Washer	ワッシャ	
35	42-1150-0	Spool pin bracket (3)	FPL 三つ穴	
36		Spool pin bracket (2)	FPL 二つ穴	
37	42-1150-0	Spool pin bracket (3)	FPL 三つ穴	
38	42-1220-0	Screw	ネジ	3
39	42-0020-0	Thread stand (2)CS-2	2本糸立て	1set
40	42-1810-0	Base	糸立て土台	1
41	42-0080-0	Thread stand (8) CS-8	8本糸立て	1set

## 22. Accessories (アクセサリー)

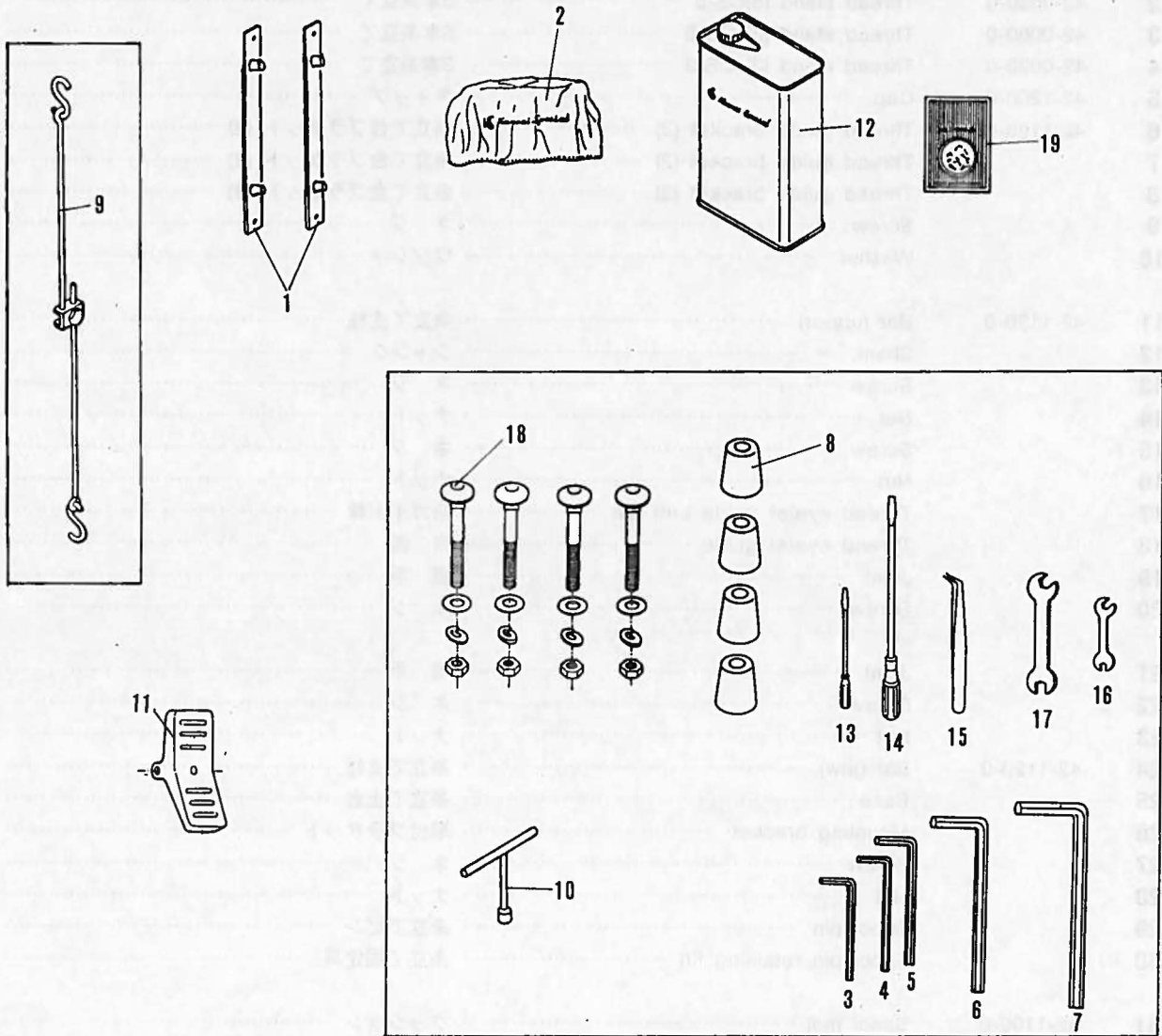

90-9000-3

No.	Part No.	Part Name	品名	Q, ty
1	25-1400-0	Machine monut bracket	タンク取付金具	2
2	28-0210-0	Machine cover	ミシン頭部ビニールカバー	1
3	28-3100-0	Wrench	6角レンチ 1.5	1
4	28-3110-0	Wrench A	6角レンチA	1
5	28-3120-0	Wrench B	6角レンチB	1
6	28-3130-0	Wrench C	6角レンチC	1
7	28-3140-0	Wrench D	6角レンチD	1
8	31-1630-0	Cushion rubber	クッションゴム	4
9	77-0060-2	Tie-rod (upper)	連結棒	1
10	28-4640-0	Wrench T	T型レンチ10ミリ	1
11	77-0010-2	Pedal	押え揚げペダル	1
12	28-6110-0	Oil tellesso	ミシンオイル	1
13	28-4510-0	Screw drive (small)	ドライバー小	1
14	28-4520-0	Screw driver	ドライバー大	1
15	28-0110-0	Tweezers	ピンセット	1
16	28-4210-0	Spanner (small)	スパナ小	1
17	28-4220-0	Spanner (large)	スパナ大	1
18	80-7510-0	Screw	クラッチモーター取付ネジ	4
19	13-0110-6	Needle UY-128GAS #11	針	10
	13-1660-6	Needle TV-7 #11 (7002-1S,8003-1S)	針 (7002-1S,8003-1S)	10
	13-3010-5	Needle SM1014B (W8004D)	針 (W8004D)	10

23. Table stand assembly diagram (テーブルスタンド据付図)

